

**TRITON**

***Topaz T80si  
thermostatic  
electric shower***



**Installation and  
operating  
instructions**



INSTALLERS PLEASE NOTE THESE INSTRUCTIONS ARE TO BE LEFT WITH THE USER

<b>CONTENTS</b>	<b>Page</b>
Important safety information	1
Introduction	2
Specifications	2
Understanding your Topaz	2
Main components	3
Electrical requirements	4 - 5
Water requirements	6
Siting of the shower	7 - 8
Fitting the shower to the wall	9
Plumbing connections	10 - 11
Electrical connections	12
Commissioning	13 - 14
Replacing the cover	15
Operating the shower	16 - 17
Operating functions	18
Instructions for installers and service engineers only	19 - 20
Spare parts	21
Fault finding	22 - 23
Guarantee, service policy, etc.	rear cover

To check the product suitability for commercial and multiple installations, please contact Triton's specification advisory service before installation.

Telephone: 0870 067 3767

Facsimile: 0870 067 3334

E mail: [technical@tritonshowers.co.uk](mailto:technical@tritonshowers.co.uk)

## PLEASE READ THIS IMPORTANT SAFETY INFORMATION

- ◆ Products manufactured by Triton are safe and without risk provided they are installed, used and maintained in good working order in accordance with our instructions and recommendations.
- ◆ **WARNING: DO NOT operate shower if frozen, or suspected of being frozen. It must thaw out before using.**
- ◆ **DO NOT operate the unit if the showerhead or spray hose becomes damaged.**
- ◆ DO NOT restrict flow out of shower by placing showerhead in direct contact with your body.
- ◆ DO NOT operate the shower if water ceases to flow during use or if water has entered inside the unit because of an incorrectly fitted cover.
- ◆ **WARNING: If restarting the shower immediately after stopping, be aware that a slug of hot water will be expelled for the first few seconds.**

### 1 GENERAL

- 1.1 Isolate the electrical and water supplies before removing the cover.
- 1.2 Read all of these instructions and retain them for later use.
- 1.3 DO NOT take risks with plumbing or electrical equipment.
- 1.4 Isolate electrical and water supplies before proceeding with the installation.
- 1.5 The unit must be mounted onto the finished wall surface (on top of the tiles). Do not tile up to unit after fixing to wall.
- 1.6 Contact Customer Service (*see back page*), if any of the following occur:
  - a) If it is intended to operate the shower at pressures above the maximum or below the minimum stated.
  - b) If the unit shows a distinct change in performance.
  - c) If the shower is frozen.
- 1.7 If it is intended to operate the shower in areas of hard water (above 200 ppm temporary hardness), a scale inhibitor may have to be fitted. For advice on the Triton Scale Inhibitor, contact Triton Customer Service.
- 1.8 The showerhead must be cleaned regularly with descaler to remove scale and debris, otherwise restrictions to the flow on the outlet of the unit will result in higher temperatures and could also cause the Pressure Relief Device in the unit to operate.
- 1.9 This product is not suitable for mounting into steam rooms or steam cubicles.

### 2 PLUMBING

- 2.1 The plumbing installation must comply with Water Regulations, Building Regulations or any particular regulations as specified by Local Water Company or Water Undertakers and should be in accordance with BS 6700.
- 2.2 The supply pipe must be flushed to clear debris before connecting to the shower unit.
- 2.3 DO NOT solder pipes or fittings within

300 mm of the shower unit, as heat can transfer along the pipework and damage components.

- 2.4 DO NOT fit any form of outlet flow control as the outlet acts as a vent for the heater can.
- 2.5 DO NOT use excessive force when making connections to the flexible hose or showerhead, finger tight is sufficient.
- 2.6 All plumbing connections must be completed before making the electrical connections.

### 3 ELECTRICAL

- 3.1 The installation must comply with BS 7671 'Requirements for electrical installations' (IEE wiring regulations), building regulations and any particular regulations as specified by the local Electrical Supply Company.
- 3.2 This appliance MUST be earthed.
- 3.3 In accordance with 'The Plugs and Sockets etc. (Safety) Regulations 1994', this appliance is intended to be permanently connected to the fixed wiring of the electrical mains system.
- 3.4 Make sure all electrical connections are tight to prevent overheating.
- 3.5 Fuses do not give personal protection against electric shock.
- 3.6 A 30mA residual current device (RCD) MUST be installed in all UK electric and pumped shower circuits. This may be part of the consumer unit or a separate unit.
- 3.7 Switch off immediately at isolating switch if water ceases to flow during use.
- 3.8 Other electrical equipment i.e. extractor fans, pumps must not be connected to the circuits within the unit.
- 3.9 Switch off at isolating switch when not in use. This is a safety procedure recommended with all electrical appliances.
- 3.10 As with all electrical appliances it is recommended to have the shower and installation checked at least every two years by a competent electrician to ensure there is no deterioration due to age and usage.

## INTRODUCTION

This book contains all the necessary installation and operating instructions for your Triton Topaz T80si thermostatic electric shower.

Take time to read this book thoroughly and familiarise yourself with all instructions BEFORE beginning installation. Please keep it for future reference.

The shower installation must be carried out by a suitably qualified person and in the sequence of this instruction book.

Care taken during the installation will ensure a long, trouble-free life from your shower.

## SPECIFICATIONS

### Electrical

Nominal power rating at 240V	Nominal power rating at 230V
8.5kW – (40A MCB rating)	7.8kW – (40A MCB rating)
9.5kW – (40A MCB rating)	8.7kW – (40A MCB rating)
10.5kW – (45A MCB rating)	9.6kW – (45A MCB rating)

### Water

Inlet connection – 15mm diameter.

Outlet connection – ½" BSP male thread.

### Entry Points

Water and cable – top, bottom or back.

### Materials

Backplate, cover, controls, showerhead – ABS.

Sprayplate – Acetal.

Elements – Minerally insulated corrosion resistant metal sheathing.

### Dimensions

Height – 335 mm

Width – 225 mm

Depth – 95 mm

### Standards and Approvals

Waterproof rating IPX4.

Complies with the requirements of current British and European safety standards for household and similar electrical appliances. Complies with requirements of the British Electrotechnical Approvals Board (BEAB).

Meets with Compliance with European Community Directives (CE).

## UNDERSTANDING YOUR TOPAZ

**IMPORTANT:** When first installed the unit will be empty. It is essential the unit should contain water before the elements are switched on. As this unit has electronic control, it is vital that the commissioning procedure is followed. Failure to carry out this operation will result in damage to the unit and will invalidate the guarantee.

### Temperature/flow rate

The temperature control on the unit can be adjusted to provide shower temperatures nominally between 35°C and 47°C. The unit will give higher and lower temperatures if given extreme supply conditions.

**Note:** The maximum flow rate for the given temperature will be greater in the summer than in winter because of ambient temperature variance of the mains water supply.

It is strongly advised to select economy power during periods of hot weather, otherwise at all other times, leave the power setting at full to provide the maximum flow rate.

### Safety cut-out

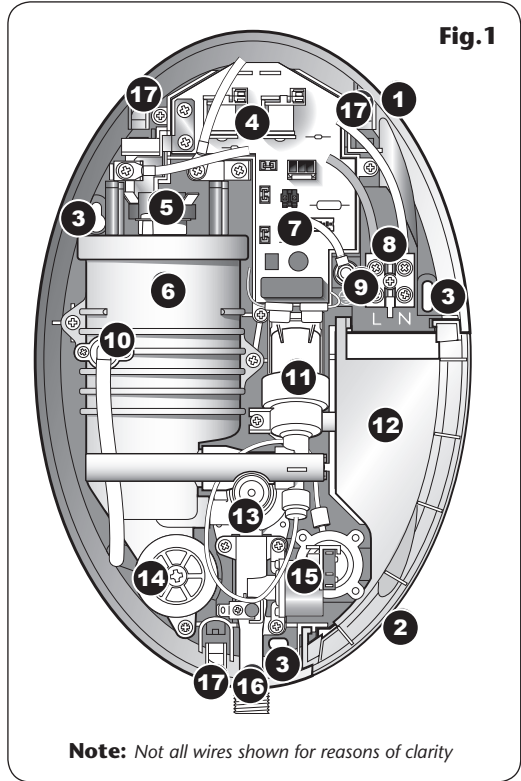
The unit is fitted with a non-resettable over-temperature safety device. In the event of abnormal operation which could cause unsafe temperatures within the unit, the device will disconnect the heating elements. It will require a visit from a qualified engineer to determine the nature of the fault and replace the safety device, once the unit has been repaired.

Replacement parts can be ordered from Customer Service. See 'spare parts' for details and part numbers.

## MAIN COMPONENTS

### Inside unit (fig.1)

1. Top cable/pipe entry
2. Bottom cable/pipe entry
3. Wall screw fixings
4. Printed Circuit Board
5. Thermal cut-out
6. Can and element assembly
7. 9-way connection socket
8. Terminal block
9. Earth connection
10. PRD
11. Solenoid valve
12. Trimplate
13. Thermostatic valve
14. Scale trap
15. Pressure switch
16. Shower outlet
17. Guide pockets

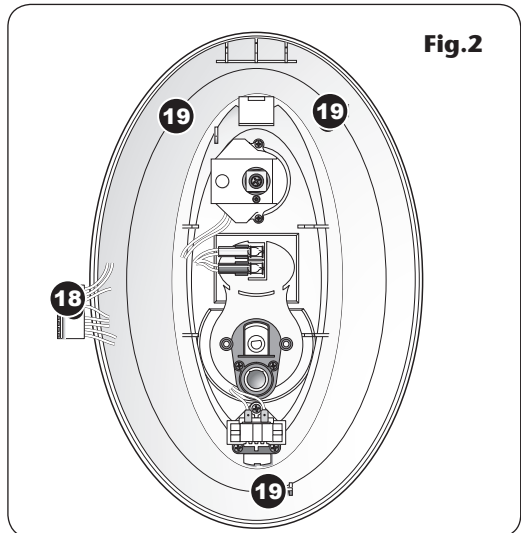


### Inside cover (fig.2)

18. 9-way connection cable
19. Cover tags

### Pack contents

- Shower unit
- Five position showerhead
- Riser rail kit
- Spray hose
- Soap dish
- Screw fixing kit
- Instructions, guarantee, etc.



## ELECTRICAL REQUIREMENTS

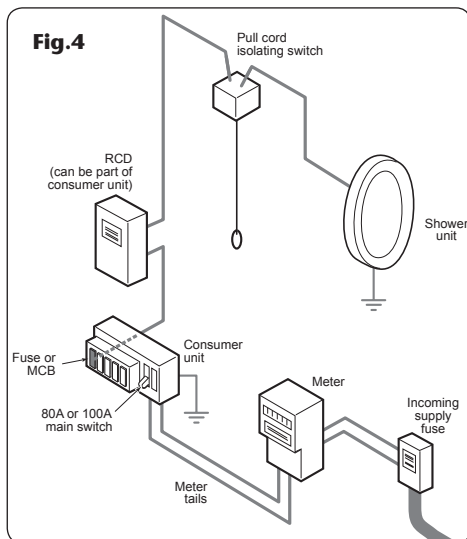
### WARNING!

#### THIS APPLIANCE MUST BE EARTHED

The installation, supply cable and circuit protection must conform with BS 7671 (IEE wiring regulations) and be sufficient for the amperage required.

The following notes are for guidance only:

- 1 The shower must only be connected to a 230-240V ac supply. If you are installing a shower with a kilowatt rating above 9kW, it is advisable to contact the local electricity supply company.
- 1.1 The electrical rating of the shower is shown on the rating label (**Fig.3**) within the unit.



- 2 Before making any sort of electrical connection within the installation make sure that no terminal is live. If in any doubt, switch off the whole installation at the mains supply and remove the correct fuse.
- 3 The shower must be connected to its own independent electrical circuit. IT MUST NOT be connected to a ring main, spur, socket outlet, lighting circuit or cooker circuit.
- 3.1 The electrical supply must be adequate for the loading of the unit and existing circuits.
- 4 Check your consumer unit (main fuse box) has a main switch rating of 80A or above and that it has a spare fuse way which will take the fuse or Miniature Circuit Breaker (MCB) necessary for the shower (**Fig.4**).
- 4.1 If your consumer unit has a rating below 80A or if there is no spare fuse way, then the installation will not be straightforward and may require a new consumer unit serving the house or just the shower.
- 4.2 You will need to contact the local electricity company. They will check the supply and carry out what is necessary.
- 5 For close circuit protection DO NOT use a rewirable fuse. Instead use a suitably rated Miniature Circuit Breaker (MCB) or cartridge fuse (**see Table A**).
- 5.1 A 30mA residual current device (RCD) must be installed in all UK electric and pumped shower circuits. This may be part of the

**Table A**

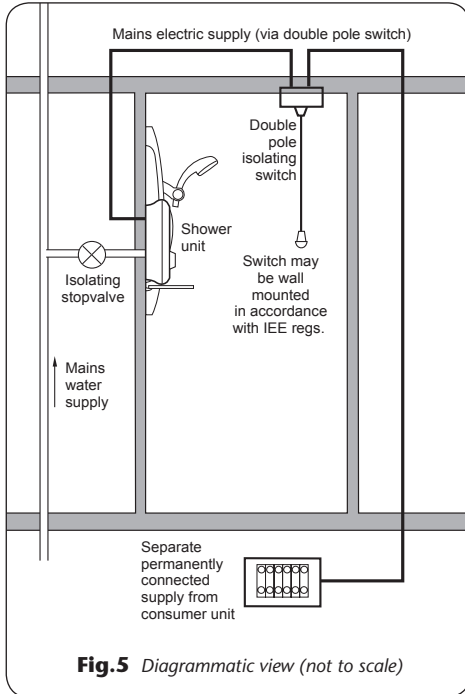
CIRCUIT PROTECTION		
unit rating	MCB	cartridge fuse
7.0kW	30/32A	30A
7.5kW	32A	35A
8.0kW	40A	35A
8.5kW	40A	45A
9.0kW	40A	45A
9.5kW	40/45A	45A
10.5kW	45A	45A

- 6 A 45 amp double pole isolating switch with a minimum contact gap of 3 mm in both poles must be incorporated in the circuit.
- 6.1 It must have a mechanical indicator showing when the switch is in the OFF position, and the wiring must be connected to the switch without the use of a plug or socket outlet.
- 6.2 The switch must be accessible and clearly identifiable, but out of reach of a person using a fixed bath or shower, except for the cord of a cord operated switch, and should be placed so that it is not possible to touch the switch body while standing in a bath or shower cubicle. It should be readily accessible to switch off after using the shower.
- 7 Where shower cubicles are located in any rooms other than bathrooms, all socket outlets in those rooms must be protected by a 30mA RCD.
- 8 The current carrying capacity of the cable must be at least that of the shower circuit protection (**see Table B**).
- 8.1 To obtain full advantage of the power provided by the shower, use the shortest cable route possible from the consumer unit to the shower.
- 8.2 It is also necessary to satisfy the disconnection time and thermal constraints which means that for any given combination of current demand, voltage drop and cable size, there is a maximum permissible circuit length.
- 9 The shower circuit should be separated from other circuits by at least twice the diameter of the cable or conduit.
- 9.1 The current rating will be reduced if the cabling is bunched with others, surrounded by thermal loft or wall insulation or placed in areas where the ambient temperature is above 30°C. Under these conditions, derating factors apply and it is necessary to select a larger cable size.
- 9.2 **In the majority of installations, the cable will unavoidably be placed in one or more of the above conditions. This being so, it is strongly recommended to use a minimum of 10mm cabling throughout the shower installation.**
- 9.3 In any event, it is essential that individual site conditions are assessed by a competent electrician in order to determine the correct cable size and permissible circuit length.

**Table B**

<b>Twin and earth PVC insulated cable CURRENT CARRYING CAPACITY</b>		
<b>installed in an insulated wall</b>	<b>in conduit or trunking</b>	<b>clipped direct or buried in a non insulated wall</b>
6mm <sup>2</sup>	6mm <sup>2</sup>	6mm <sup>2</sup>
32A	38A	46A
10mm <sup>2</sup>	10mm <sup>2</sup>	10mm <sup>2</sup>
43A	52A	63A
16mm <sup>2</sup>	16mm <sup>2</sup>	16mm <sup>2</sup>
57A	69A	85A

**Note: Cable selection is dependent on derating factors**



## WATER REQUIREMENTS

The installation must be in accordance with Water Regulations/Bylaws.

To guarantee activating the heating elements, the shower must be connected to a mains water supply with a minimum running pressure of 100kPa (1.0 bar) at a minimum flow rate of nine litres per minute with a maximum static pressure of 1 000kPa (10 bar).

**Note:** For the 10.5kW rated shower, the minimum running pressure must be 150kPa (1.5 bar) at a minimum flow rate of eleven litres per minute with a maximum static pressure of 1000kPa (10 bar). If the stated flow rates are not available, it may not be possible to achieve the ideal performance from the unit throughout the year.

**Note:** Under site conditions where the power supply is below 220 volts and the mains water pressure is above 5 bar, it is recommended to fit a pressure reducing valve set at 3.5 bar.

**Fig.5** shows a typical system layout.

**DO NOT use jointing compounds on any pipe fittings for the installation.**

During periods of high ambient temperatures it may be necessary to select a low power setting to achieve your preferred shower temperature. The water supply can be taken from a cold water storage cistern provided there is a minimum head of ten metres above the showerhead (but fifteen metres for the 10.5kW rated shower). It must be an independent supply to the shower only.

If it is intended to operate the shower at pressures above the maximum or below the minimum stated, contact Customer Service.

## SITING OF THE SHOWER

### WARNING!

**The shower must not be positioned where it will be subjected to freezing conditions.**

**IMPORTANT:** If installing onto a tiled wall always mount the unit on the surface of the tiles. NEVER tile up to the unit.

Refer to **fig.6** for correct siting of the shower.

Position the unit where it will NOT be in direct contact with water from the showerhead.

Position the shower unit vertically.

**IMPORTANT:** The unit must be mounted on a flat surface which covers the full width and length of the backplate, otherwise difficulty may arise when fitting the cover and subsequent operation of the unit may be impaired.

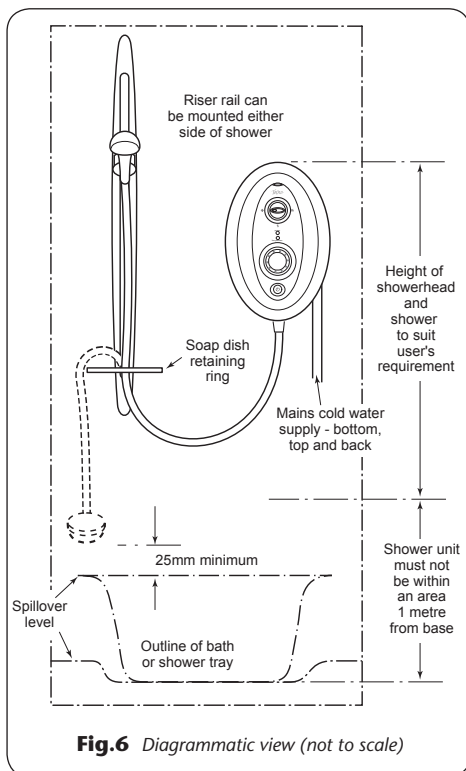
Allow enough room between the ceiling and the shower to access the cover top screws.

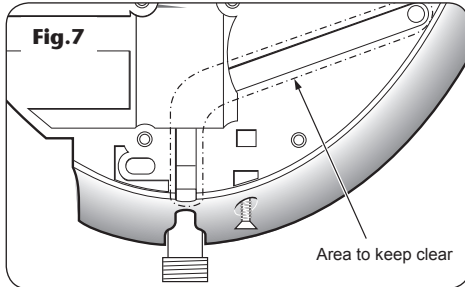
**Note:** Water regulations require the showerhead be 'constrained by a fixed or sliding attachment so that it can only discharge water at a point not less than 25 mm above the spill-over level of the relevant bath, shower tray or other fixed appliance'. The use of the supplied soap dish will in most cases meet this requirement, but if the showerhead can be placed within a bath, basin or shower tray, then a double check valve, or similar, must be fitted in the supply pipework to prevent back-flow.

### Pressure relief safety device

A pressure relief device (PRD) is designed into the shower unit which complies with European standards. The PRD provides a level of appliance protection should an excessive build up of pressure occur within the shower.

DO NOT operate the shower with a damaged or kinked shower hose, or a blocked showerhead which can cause the PRD to operate.



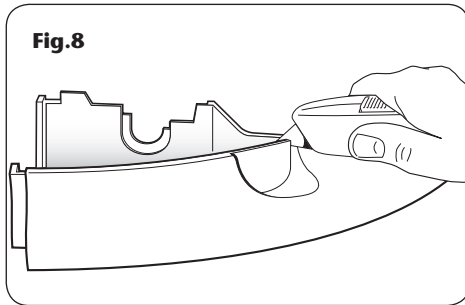


Make sure the PRD outlet at the bottom of the unit is not blocked (**fig.7**).

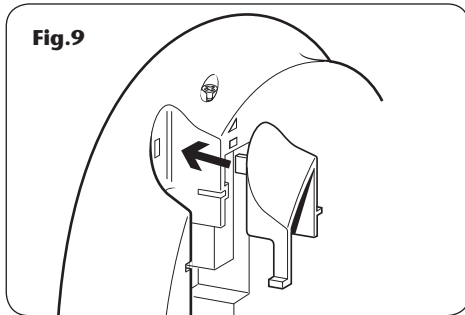
When commissioning, the showerhead must be removed from the flexible hose. Failure to follow this procedure may cause the PRD to operate.

Make sure the shower is positioned over a bath or shower tray because if the PRD operates, then water will eject from the bottom of the unit.

Should this happen, turn off the electricity and water supplies to the shower at the isolating switch and stopvalve. Contact Customer Service for advice on replacing the PRD.



**WARNING!**  
If planning to use a silicon seal around the backplate edge, do not place sealant in the area of the PRD exit channel.



## FITTING THE SHOWER TO THE WALL

**Note:** The control knob is an integral part of the cover — DO NOT attempt to remove it.

Loosen the two top and one bottom retaining screws, just enough to lift the cover from the backplate. To access the pipe and cable connections, remove the trimplate by lifting away from the backplate.

Entry positions for mains water and electrical cable are via the top, bottom or back.

**Note:** Deviations from the designated entry points will invalidate product approvals.

If bottom surface entry is required, then a hole will need to be cut out in the 'thinned section' of the trimplate using a junior hacksaw and file (**fig.8**). Make sure the hole is large enough to allow the trimplate to fit over the pipework and to snugly back onto the backplate to prevent water ingress.

If bottom or rear entry is chosen, the pipe trim will need to be fitted in the top entry position on the backplate (**fig.9**).

If installing a supply pipe from the rear or bottom, the centre of the inlet valve to the wall surface is 21 mm (**fig.10**).

**Note:** If entry is from the rear, the nut of the compression fitting will be partially behind the surface of the wall. This area MUST be left clear when plastering over the pipework in order to make the nut accessible for future adjustments.

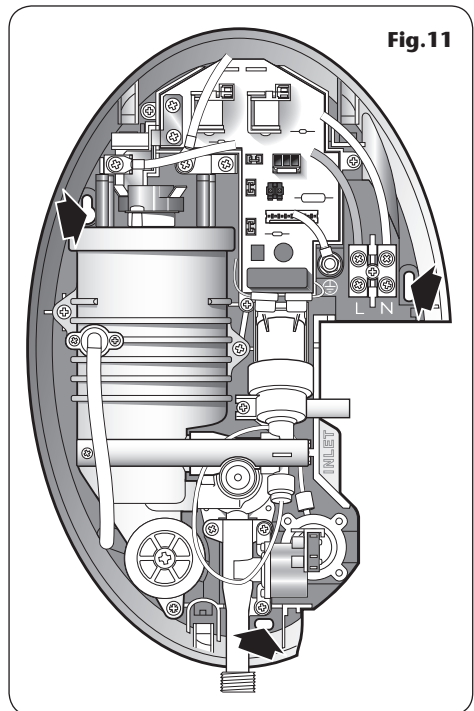
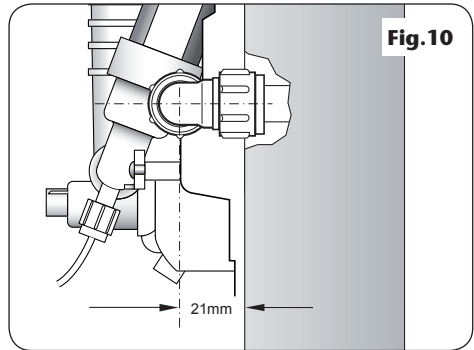
After choosing the site for the shower, use the backplate as a template and mark the three wall fixing holes (**fig.11**). Drill and plug to suit the fixing screws supplied. (*The wall plugs provided are suitable for most brick walls — use an appropriate masonry drill, but if the wall is plasterboard or a soft building block, use suitable wall plugs and an appropriate drill bit.*)

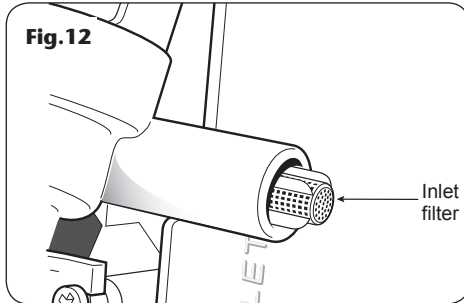
Screw the top left-hand fixing screw into position leaving the base of the screw head protruding 6 mm out from the wall. Hook the backplate over this screw, then fit the other two fixing screws into position.

Do not fully tighten the screws at this stage, as the fixing holes are elongated to allow for out of square adjustment after the plumbing connections have been completed.

### WARNING!

**Check there are no hidden cables or pipes before drilling holes for wall plugs. Use great care when using power tools near water. The use of a residual current device (RCD) is recommended.**





## **PLUMBING CONNECTIONS**

### ***Plumbing to be carried out before wiring.***

DO NOT use jointing compounds on any pipe fittings for the installation.

DO NOT solder fittings near the shower unit as heat can transfer along pipework and damage components.

Compression fittings **MUST** be used to connect to the inlet of the shower.

**Note:** An additional stopvalve (complying with Water Regulations) **MUST** be fitted in the mains water supply to the shower as an independent means of isolating the water supply should maintenance or servicing be necessary.

**IMPORTANT:** Before completing the connection of the water supply, and in compliance with Water Regulations, flush out the pipework to remove all swarf and system debris. This can be achieved by connecting a hose to the pipework and turning on the mains water supply long enough to clear the debris to waste.

**IMPORTANT:** Using a suitable sealant, always seal around the incoming pipework to prevent water entering the wall.

### ***Procedure***

Turn off the water supply either at the mains stopvalve or the isolating stopvalve. Connect the mains water supply to the inlet (**fig. 12**) of the shower via 15 mm copper, stainless steel or plastic pipe using a 15 mm x 15 mm elbow compression fitting. The plastic filter protrudes from the inlet so make sure it is in place before connection.

**The compression fitting must be pushed fully home onto the inlet to make sure of full engagement.**

**Note:** The inlet fitting is designed to enter a compression fitting only. DO NOT use push fit connectors as full engagement cannot be guaranteed. DO NOT use excessive force when making these connections.

Make sure the backplate is square on the wall and tighten the three retaining screws which hold it to the wall. Check the backplate is not distorted when screws are fully tightened.

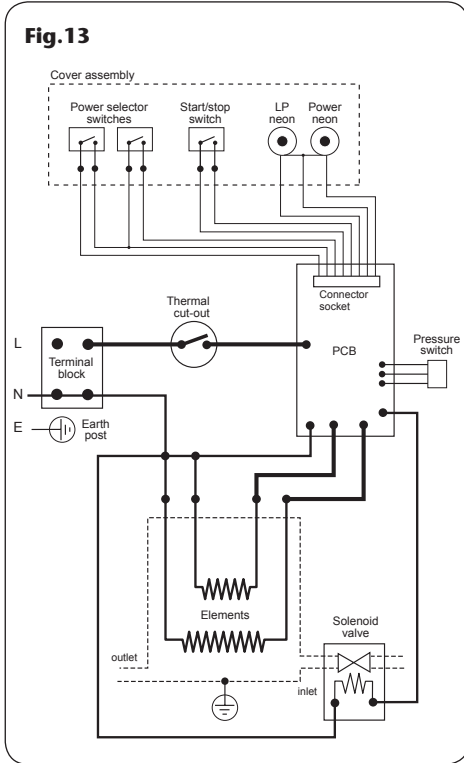
Turn on the mains water supply and check for leaks in the pipework connection to the shower.

**Note:** At this stage no water can flow through the unit.

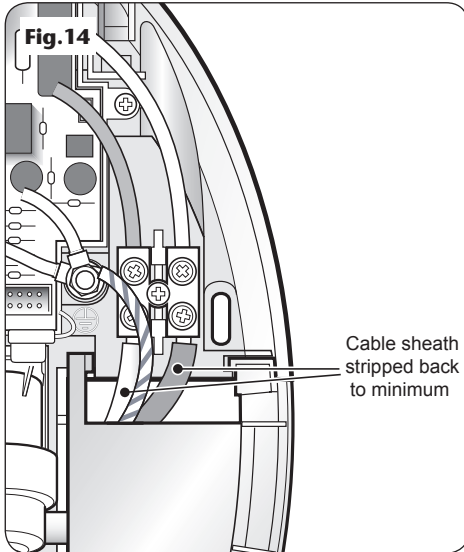
**WARNING!**

**The outlet of the shower acts as a vent and must not be connected to anything other than the hose and showerhead supplied.**

**Fig.13**



**Fig.14**



## ELECTRICAL CONNECTIONS

SWITCH OFF THE ELECTRICITY SUPPLY AT THE MAINS.

**Fig.13** shows a schematic wiring diagram.

The cable entry points are top, bottom or back. The cable can be surface clipped, hidden or via 20 mm conduit.

**Note:** Conduit entry can only be from rear.

Route the cable into the shower unit and connect to the terminal block as follows:

Earth cable to terminal marked **E** 

Neutral cable to terminal marked **N**

Live cable to terminal marked **L**

**IMPORTANT:** Fully tighten the terminal block screws and check that no cable insulation is trapped under the screws. Loose connections can result in cable overheating.

**Note:** The supply cable earth conductor **MUST** be sleeved (**fig.14**). The outer sheath of the supply cable must be stripped back to the minimum.

The supply cable must be secured either by routing through conduit or in trunking or by embedding in the wall, in accordance with current IEE regulations.

The use of connections within the unit to supply power to other equipment i.e. extractor fans, pumps etc. will invalidate the guarantee.

**DO NOT switch on the electricity supply until the cover has been fitted.**

**Note:** The elements on UK models are to 240V specifications and will give a lower kW rating if the voltage supply is below 240V.

## COMMISSIONING

### WARNING!

**Before normal operation of the shower, it is essential the following commissioning procedure is completed correctly.**

The first operation of the shower is intended to flush out any remaining unit debris, and to make sure the heater unit contains water before the elements are switched on. This operation must be carried out with the flexible hose screwed to the outlet but without the showerhead attached. Make sure the outlet of the flexible hose is directed to waste.

Refit the trimplate by carefully guiding into the locating slots in the backplate.

**At this stage temporarily fit the cover to carry out the commissioning procedure.**

- Offer the cover to the unit.
- Make sure the valve spindle has the 'flat' and keyway slot uppermost at the 12 o'clock position (**fig.15**).
- Make sure the temperature control knob on the cover has the 'Triton' logo horizontal with the blue/red graphics at the top (**fig.16**). The knob 'flat' inside the cover should be uppermost.

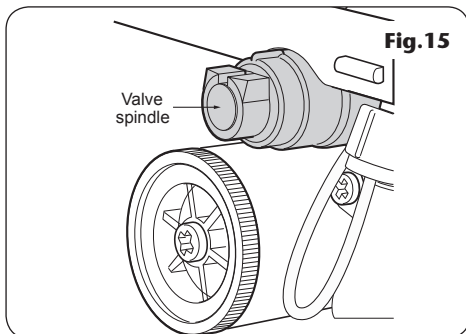
Plug the 9-way connection cable into the control PCB (**fig.17**). Take care to fit the connection cable the correct way. Note that the connector has a lip on the bottom edge.

Carefully locate the cover tags into the guide pockets on the backplate and make sure the wires are not trapped.

Guide the cover into position so that the control spindle locates correctly (the 'flats' make sure the spindle and knob only fit one way).

While applying slight pressure to the front cover, secure in position with the three retaining screws.

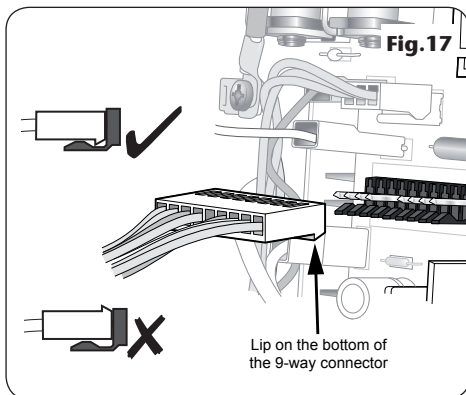
Fit the flexible hose (but *without* the showerhead) to the shower outlet checking the outlet of the hose is directed to waste. Check the supplied sealing washer is in place.



**Fig.15**

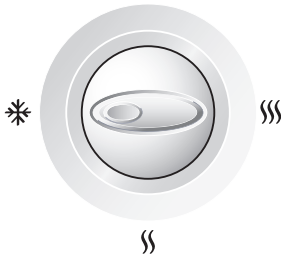


**Fig.16**



**Fig.17**

Fig.18



**IMPORTANT:** Make sure the STOP/START button is not depressed in the cover, otherwise water will flow as soon as the electricity supply is turned on.

**Note:** The power selector is locked in the COLD position for the commissioning procedure (**fig.18**).

Turn on the water supply to the shower at the isolating stop valve. Switch on the electricity supply to the shower at the isolating switch. The power indicator will light.

Press the STOP/START button and wait until water starts to flow from the flexible hose.

It will take about thirty seconds for a smooth flow of water to be obtained while air and any debris is being flushed from the shower.

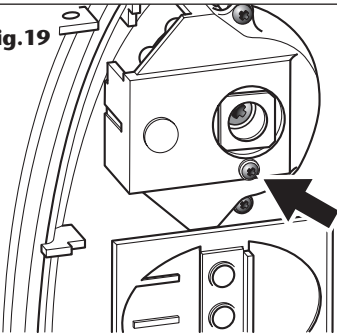
Upon completion of the flushing out procedure press the STOP/START button to stop the water flow.

Disconnect the electricity supply to the shower at the isolating switch.

Unscrew the cover retaining screws and lift the cover from the backplate. Remove the 9-way connection cable from the control PCB.

On the rear of the cover, within the power selector assembly (**fig.19**) is a locking screw. Using a suitable screwdriver, remove the locking screw in the rear of the power control. This will unlock the power selector.

Fig.19



## REPLACING THE COVER

**IMPORTANT:** Before finally fitting the cover, the following steps must be taken:

- a) Check all plumbing connections are watertight.
- b) Check terminal block screws are fully tightened.
- c) Make sure pipe and cable entering the unit do not prevent the cover locating correctly to the backplate.
- d) Make sure the valve spindle has the 'flat' and keyway slot uppermost at the 12 o'clock position (**fig.15**).
- e) Make sure the temperature control knob on the cover has 'TRITON' horizontal with the blue/red graphics at the top (**fig.16**). The knob 'flat' inside the cover should be uppermost.

Offer the cover to the unit. Carefully locate the cover tags into the guide pockets on the backplate and check that the wires are not trapped. Guide the cover into position so that the control spindle locates correctly (the 'flats' make sure the spindle and knob only fit one way).

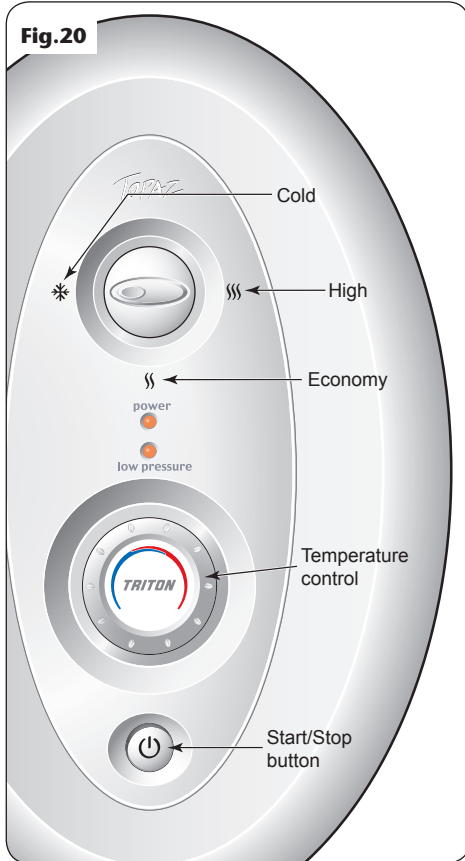
While applying slight pressure to the front cover, secure in position with the three retaining screws.

Once the riser rail kit is installed and the showerhead fitted, the shower is ready for normal operation.

### WARNING!

**If using a silicon seal around the backplate edge, make sure the PRD exit behind the outlet pipe is kept clear (fig.7).**

Fig.20



## OPERATING THE SHOWER

### WARNING!

**Before normal operation of the shower, it is essential that the commissioning procedure has been completed correctly.**

### To start the shower

Press the START/STOP button and water will flow.

### To stop the shower

Press the 'START/STOP' button and the phased shutdown will begin. Water continues to flow for a few seconds, flushing out any remaining hot water. This prevents the next immediate user receiving a slug of hot water if standing under the showerhead when starting the shower.

### To use the power selector

The power selector has three positions — COLD, ECONOMY and HIGH — as shown (fig.20).

\* The blue symbol is for COLD water only. Adjusting the temperature control at this setting has no effect on the force of water from the showerhead and it will not alter the water temperature.

}} The double red symbol is the ECONOMY setting for using less power when the ambient mains water temperature is high during the summer months. Temperature adjustment at this setting is via the temperature control.

**Note:** If the stated flow rate required for the unit cannot be met due to low water pressure, it will be necessary to operate the unit on this setting during the warmer months because of flow rate limitations entering the unit.

}}} The treble red symbol is the HIGH setting which allows the highest flow achievable for your preferred temperature. This setting should normally be regarded as optimum shower performance throughout the year. Temperature adjustment at this setting is via the temperature control.

**To adjust the shower temperature**

The water temperature is altered by increasing or decreasing the flow rate of the water through the shower via the temperature control.

After obtaining your preferred shower temperature, the control can be left as the normal setting and should only need adjusting for seasonal changes in the ambient water temperature.

**Note:** The preferred position on ECONOMY will give a different temperature to the same position on HIGH.

**To decrease the shower temperature**

Turn the temperature control anti-clockwise to lower the showering temperature (**fig.21**).

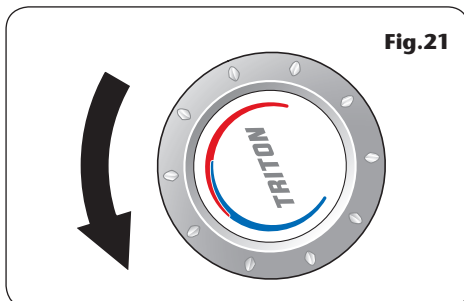
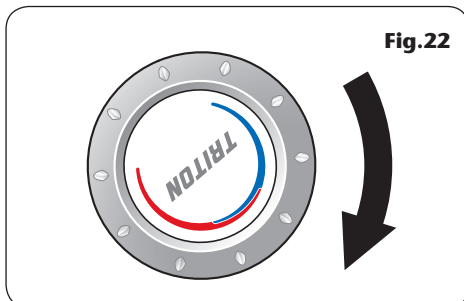
**To increase the shower temperature**

Turn the temperature control clockwise to raise the showering temperature (**fig.22**).

**Note:** It is advisable to be certain that the showering temperature is satisfactory by testing with your hand BEFORE stepping under the showerhead.

There will always be a time delay of a few seconds between selecting a temperature and the water reaching the selected stable temperature.

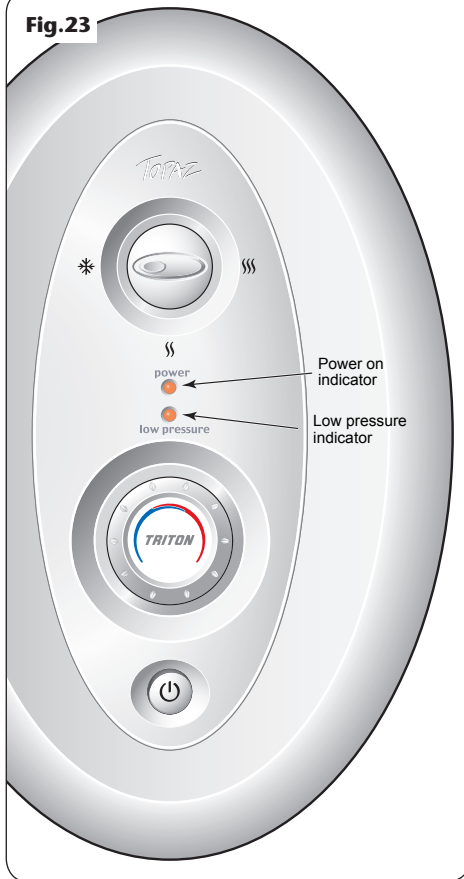
**CAUTION:** It is recommended that persons who may have difficulty understanding or operating the shower controls should not be left unattended while showering. Special consideration should be given to young children and the less able bodied.

**Fig.21****Fig.22****WARNING!**

**This appliance is not intended for use by young children or infirm persons unless they have been adequately supervised by a responsible person to ensure that they can use the appliance safely.**

**Young children should be supervised to ensure that they do not play with the appliance.**

Fig.23



## OPERATING FUNCTIONS (fig 23)

### Power on indicator

When the electricity supply to the shower is switched on at the isolating switch, the POWER indicator will light.

### Low pressure indicator

A lit indicator means the water pressure has fallen below the minimum required for correct operation of the shower. In this state the low pressure cut-out has operated. This switches off power to the heating elements preventing maintained temperature rises (water will continue to flow). Power will automatically be restored when adequate water pressure returns. If the indication fluctuates between on and off, this means there is just enough pressure and operating difficulties may be encountered.

### Safety cut-out

The unit is fitted with a thermal cut-out safety device. In the event of abnormal operation which could cause unsafe temperatures within the unit, the device will disconnect the heating elements. It will require a visit from a qualified engineer to discover the nature of the fault and replace the safety device, once the unit has been repaired.

**INSTRUCTIONS FOR INSTALLERS AND SERVICE ENGINEERS ONLY****CLEANING THE INLET FILTER****WARNING!**

**After any servicing of mains water supply, always make sure the unit is started on COLD in order to purge any air in the pipework.**

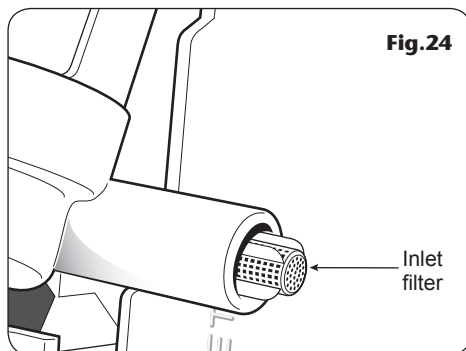
It is recommended that the filter is periodically cleaned in order to maintain the performance of the shower. It is essential that this operation is carried out by a competent person.

**IMPORTANT:** Before servicing, Switch off the electricity supply at the mains.

Remove the cover. The inlet filter is situated in the solenoid inlet (**fig.24**) and can be removed to clean.

To gain access to the filter, remove the trimplate then disconnect and remove the compression fitting. Also, depending on the incoming pipework arrangements, if there is not enough slack in the pipework, it could mean the removal of the unit from the wall.

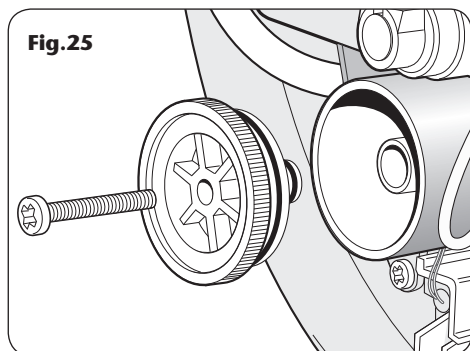
When cleaning the plastic filter, DO NOT use a sharp object, as it will cause damage. It is preferable to use an old toothbrush or similar.



---

**INSTRUCTIONS FOR INSTALLERS AND SERVICE ENGINEERS ONLY**


---


**CLEANING THE SCALE TRAP**

It is recommended in hard water areas, the scale trap is periodically cleaned to maintain the performance of the shower. It is essential that this operation is carried out by a competent person.

**IMPORTANT:** Before servicing, Switch off the electricity supply at the mains.

Remove the cover and unplug the ribbon cable. The scale trap is located at the lower left-hand side of the unit. Unscrew the single central screw (**fig.25**) then pull off the cap complete with 'O' rings.

Be aware of water discharging as the heater can exhausts.

Clean out the trap and remove all sediment. Flush the can through by leaving the cap off and switching on the power at the isolating switch.

**Note:** Make sure the water that flows out of the scale trap will safely flow to waste.

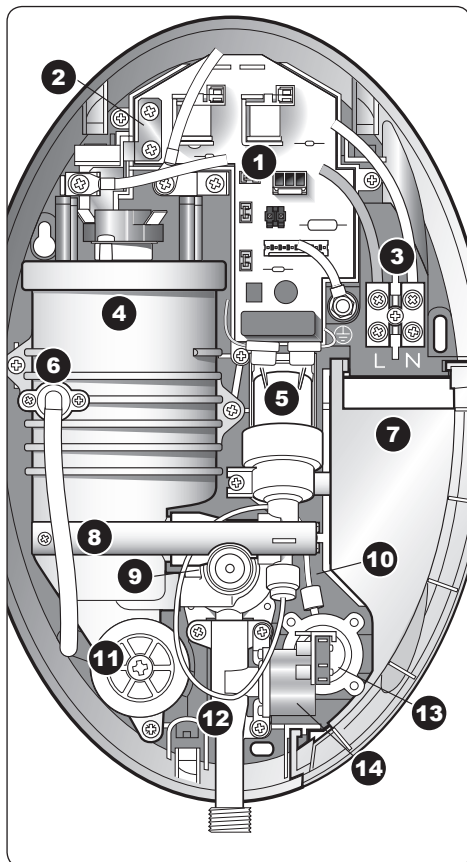
Switch the power off at the isolating switch. Replace the cap making sure the 'O' rings are in place and free from debris. Secure with the central screw.

Switch the power back on again at the isolating switch to enable the can to fill with water. Check for water leakage at the scale trap. When water flows smoothly from the showerhead, stop the flow by switching off the power at the isolating switch.

Reconnect the ribbon cable and replace the cover and secure with the three screws.

**SPARE PARTS**

<b>Ref. Description</b>	<b>Part No.</b>
<b>1.</b> Printed circuit board 8.5 & 9.5kW 10.5kW	7073211 7073215
<b>2.</b> Copper bus bar	7023005
<b>3.</b> Terminal block & wires Terminal block	S07740901 22011410
<b>4.</b> Heater can assembly 8.5kW c/w restrictor & TCO	83307080
Heater can assembly 9.5kW c/w restrictor & TCO	83307090
Heater can assembly 10.5kW c/w restrictor & TCO	83307100
- Restrictor 8.5kW	22010400
- Restrictor 9.5kW	22010310
- Restrictor 10.5kW	22010410
<b>5.</b> Solenoid valve assembly and 'O' ring	83307110
<b>6.</b> Pressure Relief Device	82800450
<b>7.</b> Trimplate	7052989
<b>8.</b> Can brace	7053008
<b>9.</b> Thermostatic valve and 'O' rings (4)	83307130
<b>10.</b> Connecting tube	22010260
<b>11.</b> Scale trap cover c/w 'O' rings and screw	83307140
<b>12.</b> Outlet pipe	7053196
<b>13.</b> Pressure switch & wires	S07741000
<b>14.</b> Pressure switch & 'O' ring	83307120
- Cover assembly c/w knobs & buttons & wiring loom	S07740600
- Cover wiring loom	P07741200
- Earth wire	2160454
- Pressure switch wire & microswitch	2160475
- Power PCB carrier	7052991
- Rubber microswitch cover	7063046
- Inlet filter	7053009



## FAULT FINDING

**IMPORTANT:** Switch OFF the electricity at the mains supply and remove the circuit fuse before attempting any fault finding inside the unit.

<b>Problem/Symptom</b>	<b>Cause</b>	<b>Action/Cure</b>
<b>1</b> Shower inoperable.	<b>1.1</b> Interrupted power supply.	<b>1.1.1</b> Blown fuse or circuit breaker. Check supply. Renew or reset fuse or circuit breaker. If it fails again, consult a qualified electrician.
	<b>1.2</b> Unit malfunction.	<b>1.1.2</b> Power cut? Check other appliances and if necessary, contact local Electric Supply Co. <b>1.2.1</b> Have unit checked by suitably qualified electrician or contact Customer Service.
	<b>1.3</b> Cover not plugged in.	<b>1.3.1</b> Switch off the electric supply, remove the shower cover and plug in power cable.
<b>2</b> Water flows when isolating switch is switched on.	<b>2.1</b> Unit malfunction.	<b>2.1.1</b> Contact Customer Service.
<b>3</b> Water too hot.	<b>3.1</b> Temperature control incorrect setting.	<b>3.1.1</b> Turn temperature control anti-clockwise.
	<b>3.2</b> Unit malfunction.	<b>3.2.1</b> Contact Customer Service.
<b>4</b> Unstable shower temperature or flow.	<b>4.1</b> Blockages.	<b>4.1.1</b> Clean showerhead. Check inlet filter.
	<b>4.2</b> Unit malfunction.	<b>4.2.1</b> Contact Customer Service.
<b>5</b> Water too cool or cold.	<b>5.1</b> Temperature control incorrect setting.	<b>5.1.1</b> Turn clockwise.
	<b>5.2</b> Unit malfunction.	<b>5.2.1</b> Contact Customer Service.
	<b>5.3</b> Safety cut-out operated.	<b>5.3.1</b> The thermal safety cut-out device has operated. Have unit checked by suitably qualified electrician or contact Customer Service.
<b>6</b> Water continues to flow when unit is isolated at isolating switch.	<b>6.1</b> Debris in solenoid.	<b>6.1.1</b> Contact Customer Service for advice.

## FAULT FINDING

### **Problem/Symptom Cause**

**7** Pressure relief device has operated (water ejected from PRD tube).

**7.1** Blocked showerhead.

**7.2** Twisted/blocked flexible shower hose.

**7.3** Showerhead not removed when commissioning.

### **Action/Cure**

**7.1.1** Clean or replace blocked showerhead cartridge and then fit a new PRD.

**7.2.1** Check for free passage through hose. Replace the hose if necessary, then fit new PRD.

**7.3.1** Fit new PRD. Commission unit with showerhead removed.

**Note:** Identify cause of operation before fitting new PRD unit. When fitting a new PRD, follow the commissioning procedure.

**It is advised all electrical maintenance/repairs to the shower should be carried out by a suitably qualified person.**

**In the unlikely event of a fault occurring please contact Triton Customer Service. Do not remove the shower from the installation.**





## Service Policy

In the event of a complaint occurring, the following procedure should be followed:

- 1 Telephone Customer Service on 0870 067 3333 (0845 762 6591 in Scotland and in Northern Ireland), having available the model number and power rating of the product, together with the date of purchase.
- 2 Triton Customer Service will be able to confirm whether the fault can be rectified by either the provision of a replacement part or a site visit from a qualified Triton service engineer.
- 3 If a service call is required the unit must be fully installed for the call to be booked and the date confirmed. In order to speed up your request, please have your postcode available when booking a service call.
- 4 It is essential that you or an appointed representative (who must be a person of 18 years of age or more) is present during the service engineer's visit and receipt of purchase is shown.
- 5 A charge will be made in the event of an aborted service call by you but not by us, or where a call under the terms of guarantee has been booked and the failure is not product related (i.e. scaling and furring, incorrect water pressure, pressure relief device operation, electrical installation faults).
- 6 If the product is no longer covered by the guarantee, a charge will be made for the site visit and for any parts supplied.
- 7 Service charges are based on the account being settled when work is complete, the engineer will then request payment for the invoice. If this is not made to the service engineer or settled within ten working days, an administration charge will be added.

## Replacement Parts Policy

**Availability:** It is the policy of Triton to maintain availability of parts for the current range of products for supply after the guarantee has expired. Stocks of spare parts will be maintained for the duration of the product's manufacture and for a period of five years thereafter.

In the event of a spare part not being available a substitute part will be supplied.

**Payment:** The following payment methods can be used to obtain spare parts:

- 1 By post, pre-payment of pro forma invoice by cheque or money order.
- 2 By telephone, quoting credit card (MasterCard or Visa) details.
- 3 By website order, [www.tritonshowers.co.uk](http://www.tritonshowers.co.uk)

Triton Showers  
Triton Road  
Nuneaton  
Warwickshire CV11 4NR

*Triton is a division of Norcross Group (Holdings) Limited*

## TRITON STANDARD GUARANTEE

Triton guarantee this product against all mechanical and electrical defects arising from faulty workmanship or materials for a period of two years for domestic use only, from the date of purchase, provided that it has been installed by a competent person in full accordance with the fitting instructions.

Any part found to be defective during this guarantee period we undertake to repair or replace at our option without charge so long as it has been properly maintained and operated in accordance with the operating instructions, and has not been subject to misuse or damage.

This product must not be taken apart, modified or repaired except by a person authorised by Triton. This guarantee applies only to products installed within the United Kingdom and does not apply to products used commercially. This guarantee does not affect your statutory rights.

### What is not covered:

- 1 Breakdown due to: **a)** use other than domestic use by you or your resident family; **b)** wilful act or neglect; **c)** any malfunction resulting from the incorrect use or quality of electricity, gas or water or incorrect setting of controls; **d)** faulty installation.
- 2 Repair costs for damage caused by foreign objects or substances.
- 3 Total loss of the product due to non-availability of parts.
- 4 Compensation for loss of use of the product or consequential loss of any kind.
- 5 Call out charges where no fault has been found with the appliance.
- 6 The cost of repair or replacement of pressure relief devices, showerheads, hoses, riser rails and/or wall brackets, isolating switches, electrical cable, fuses and/or circuit breakers or any other accessories installed at the same time.
- 7 The cost of routine maintenance, adjustments, overhaul modifications or loss or damage arising therefrom, including the cost of repairing damage, breakdown, malfunction caused by corrosion, furring, pipe scaling, limescale, system debris or frost.

**Customer Service:** ☎ 0870 067 3333

**Scottish and Northern Ireland  
Customer Service:** ☎ 0845 762 6591

**Trade Installer Hotline:** ☎ 0870 067 3767  
**Fax:** 0870 067 3334

[www.tritonshowers.co.uk](http://www.tritonshowers.co.uk)

**E mail:** [technical@tritonshowers.co.uk](mailto:technical@tritonshowers.co.uk)

**Extended Warranty AVAILABLE NOW. Call 0870 067 3333 for more details.**