

TRITON

T550i power shower pump

ACTIVATE YOUR
FREE
PARTS AND LABOUR GUARANTEE
NOW
www.tritonshowers.co.uk
TRITON

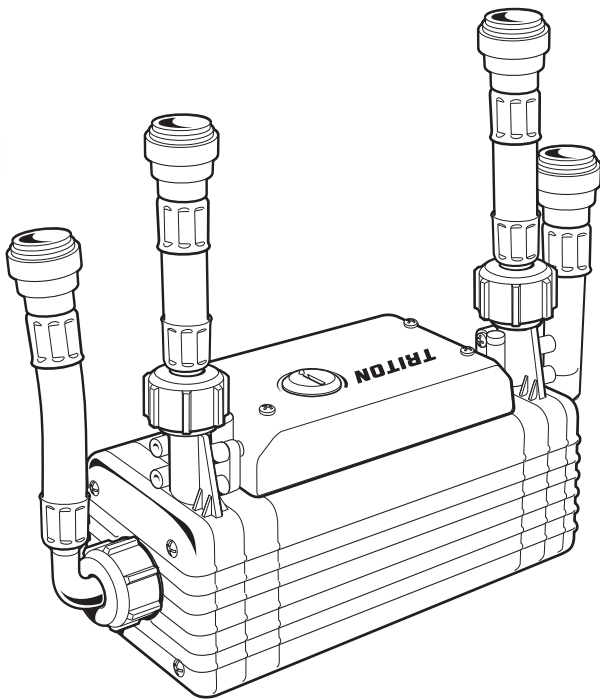

Installation and operating instructions

INSTALLERS PLEASE NOTE THESE INSTRUCTIONS ARE TO BE LEFT WITH THE USER

CONTENTS	Page
Plumbing and electrical notes.....	1
Introduction	2
Safety warnings	2
Key to main components	3
Water requirements	4
Electrical requirements.....	5
Siting of the pump	5
Installation	6
Variable speed control	9
Commissioning.....	9
Spare parts	11
Fault finding	12
Guarantee, Service Policy, Etc.	Rear cover

1 PLUMBING NOTES

- 1.1 All installations must comply with Water Regulations/Byelaws.
- 1.2 Supply pipes must be flushed thoroughly to clear debris before connecting to the pump and shower.
- 1.3 DO NOT connect the pump unit to the mains cold water supply as it would damage the unit and also, the installation would be in breach of the guidance notes contained in '1' above.
- 1.4 DO NOT use excessive force when making connections to the flexible connector hoses.
- 1.5 DO NOT turn on the electrical supply to the pump until the plumbing connections and commissioning procedure have been completed. **The pump must not be operated dry without water.**
- 1.6 DO NOT solder pipes or fittings within 300mm of the pump, as heat transfer can damage the components.
- 1.7 A dedicated cold water supply must be taken directly from the cold water cistern to the pump. This draw-off must be on the opposite side of the cistern to the float operated valve.
- 1.8 The action of the pump is to increase the flow rate. If the supply pipework cannot handle the resulting flow rate then:
 - 1.8.1 The anticipated flow rate may not be achieved.
 - 1.8.2 Air may be drawn into the hot supply from the vent pipe causing spluttering and temperature fluctuations at the sprayhead.
- 1.9 A high level hot feed pipe run must not rise above the level of water in the cistern. To reduce the risk of air locks pipes should be run level with or below the base of the cistern.
- 1.10 Standard gate valves or full way lever valves MUST be fitted on the hot and cold water supplies to the pump as an independent means of isolating the water supplies should maintenance or servicing be necessary.

DO NOT use stop taps or ball-o-fix type valves which restrict flow.

- 1.11 If the pump unit is installed on a common supply which feeds an adjacent tap, the maximum static inlet pressure for the unit will, under certain circumstances be exceeded. The action of closing the tap can cause a pulse in the supply pressure which may result in damage to the unit. This can be resolved by the installation of a suitably sized mini expansion vessel, sited as close as possible to the tap and pressurised to 50kPa (0.5 bar).

2 ELECTRICAL NOTES

- 2.1 The installation must comply with BS 7671 'Requirements for electrical installations' (IEE wiring regulations). Ensure the incoming hot and cold water supplies to the pump are adequately earth bonded.
- 2.2 DO NOT turn on the electrical supply to the pump until the plumbing connections have been completed. **The pump must not be operated dry without water.**
- 2.3 The mains supply must be 230-240V, at 50Hz, connected to the pump via a double pole switched 3 Amp fused connection unit (not supplied) with a minimum 3mm contact separation gap in each pole.
- 2.4 In accordance with 'The Plugs and Sockets etc. (Safety) Regulations 1994', the pump is intended to be permanently connected to the fixed electrical wiring of the mains system.
- 2.5 To enhance electrical safety a 30mA residual current device (RCD) should be installed in all UK electric and pumped shower circuits. This may be part of the consumer unit or a separate unit.

Replacement parts can be ordered from Triton Customer Service. See 'spare parts' for details.

INTRODUCTION

This book contains all the necessary fitting and operating instructions for your Triton twin impeller power shower pump. Please read them carefully.

This product is rated at:
15 minutes on / 60 minutes off.

Care taken during the installation will ensure a long and trouble free life from your unit.

IMPORTANT: All plumbing connections must be completed before making the electrical connections.

Please read through the whole of this book before beginning your installation.

SAFETY WARNINGS

- a. Under no circumstances must this pump be connected to a mains cold water supply. Failure to comply will invalidate the guarantee.
- b. The shower pump MUST NOT be used if suspected of being frozen.
- c. The pump must be earthed.
- d. Switch off immediately at isolating switch if water ceases to flow during use.
- e. DO NOT operate the unit outside the guidelines laid out in "site requirements".
- f. This pump is to be used for providing water to a shower only.

In the interest of electrical safety a 30mA residual current device (RCD) should be installed in all UK electric and pumped shower circuits. This may be part of the consumer unit or a separate unit.

KEY TO MAIN COMPONENTS**Pump (fig.1)**

- 1 Inlet connector hose
- 2 Outlet connector hose
- 3 Integral flow switch
- 4 Variable speed control
- 5 PCB cover

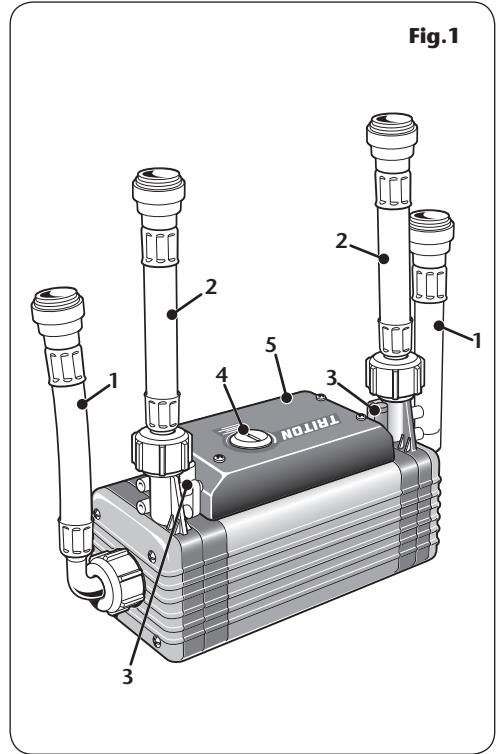

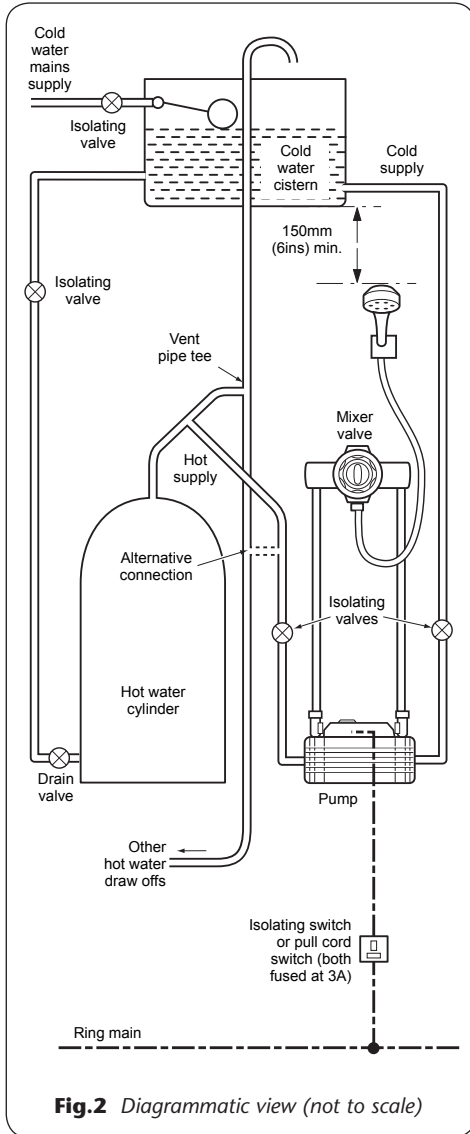

Max Head	100kPa	(10m)
Min Head	1.5kPa	(0.15m)
Max Total Head	30m	

WATER REQUIREMENTS

The installation must be in accordance with Water Regulations and Byelaws.

For correct operation of this shower pump in addition to the shower unit, water must be gravity fed at nominally equal pressures directly from the same cold water storage cistern (the hot water being fed to the pump via the hot water cylinder).

The cold water cistern and hot water cylinder must each have a minimum capacity of 114 litres (25 galls). It is advisable to check that the infill rate from the float operated valve meets the output requirements. If the cistern supplies water to a number of cold outlets it is advisable to increase the stored water capacity to 230 litres (50 galls).

Both hot and cold water supplies to the pump must be direct and not significantly affected by any other outlets or connections.

(Fig.2) shows a recommended installation where the hot water supply for the shower is made via a tee connection on the underside of the rising horizontal section of pipework from the cylinder. Alternatively, the connection can be taken from the hot supply pipe to other outlets as long as it is the first draw-off below the ventilation pipe tee.

THE PUMP MUST NOT BE CONNECTED TO THE MAINS COLD WATER SUPPLY.

DO NOT connect into the rising vent pipework.

The pump must be positioned below the cold water cistern and not placed in areas where it will be subject to freezing conditions.

To ensure correct operation of the flow switches, all pipework must be below the cold water cistern and the sprayhead must be at least 150mm below the bottom of the cold water cistern.

In situations where this requirement cannot be met, contact Triton Customer Service for advice.

If used with a combination cylinder, the cold water cistern must have a capacity of at least 114 litres (25 galls) to avoid starvation of water to the pump, and a minimum head of water of 150 mm.

DO NOT use jointing compounds on any pipe fittings.

WARNING!

THIS PUMP IS DESIGNED TO SUPPLY WATER TO A SHOWER ONLY.

ELECTRICAL REQUIREMENTS

WARNING!
THE PUMP MUST BE EARTHED.

The pump must be connected to a 230 – 240V A.C. electrical supply, via a double pole switch with at least 3mm contact separation. This can be a ceiling mounted pull cord switch in the shower room, or a wall mounted switch in an adjacent room.

The pump installation should be fused at 3 amps.

It is recommended that a suitable residual current device (RCD) is fitted in the electricity supply circuit to this appliance.

Note: The installation and wiring must comply with current IEE regulations.

When installed in any room containing a fixed bath or shower, the pump **MUST** be located and concealed inside a suitable cupboard, built-in unit or other enclosure, in order so the pump cannot be sprayed with water, and such that a person using a fixed bath or shower cannot touch the pump without using tools.

SITING OF THE PUMP

WARNING!
THE UNIT **MUST NOT BE POSITIONED** WHERE IT WILL BE SUBJECT TO FREEZING CONDITIONS.

The pump **MUST ALWAYS** be positioned **BELOW** the cold water cistern and be situated as close as possible to the hot water cylinder. It is recommended that the cold water supply is taken from the opposite side of the cistern to the float operated valve to prevent air entrapment in the supply.

Position the pump in a dry area and ensure it is accessible for any maintenance etc. that may be necessary.

IMPORTANT: Ensure the ventilation slots on the underside of the pump are free from obstructions.

The hot water supply **MUST NOT** exceed 65°C (149°F).

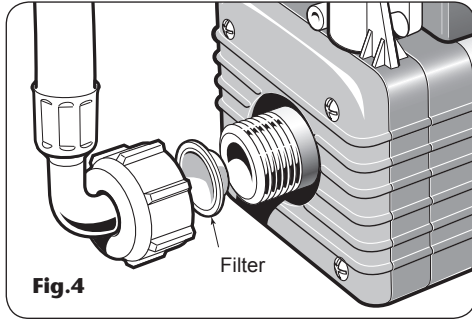

Fig.4

INSTALLATION

Before commencing installation of the pump, ensure the site conditions have been complied with fully.

Also note the following:

- Pipework to precede wiring.
- The pump must be positioned in a dry area, ideally in the linen/airing cupboard. It must be well ventilated and not covered with towels and sheets etc.
- Do not use with a combination water tank system unless the cold water storage tank has capacity of 114 litres (25 galls) or more.
- To assist in clearing air bubbles from the system avoid using sharp bends where possible. Flexible/swept fittings or formed pipework is recommended.
- Ensure that all water supplies are isolated before connection. Gate valves or full way lever valves must be fitted immediately prior to the pump. It is also advisable to fit a drain off point on the lowest part of the system.
- NEVER use any form of soldered fittings on the shower pump as this will damage the unit and invalidate the guarantee.
- NEVER use solder within 300mm of the pump or expose parts to a hot torch.
- Ensure mains electricity supply is SWITCHED OFF before commencing electrical connections.
- **DO NOT OPERATE THE PUMP DRY.** This may cause damage to the seals and will invalidate the guarantee.

Note: The pump motor has automatically resetting thermal overload protection.

Procedure

- a Turn off mains water and electrical supplies. Drain the cold water cistern and hot water cylinder and make a suitable connection to the hot water supply.
- b Position the pump horizontally (with the outlet ports in the upright position) with the feet on a solid base so that it will not transmit vibration.

Note: The pump MUST ONLY be placed in the horizontal position.

- c Connect the inlet flexible connectors to the inlet ports of the pump ensuring the filters are in position on the inlet sides (**fig.4**).

The hot and cold supplies can be connected to either end of the pump.

- d Connect the outlet flexible connectors to the outlet ports of the pump.
- e Connect the hot and cold feed pipes from the mixer valve to the outlet flexible push-in connectors.
- f At this stage, DO NOT connect the hot and cold water supplies from the cistern and cylinder to the inlet flexible push-in connectors. Wait until the commissioning procedure has been completed.

Note: Do not overtighten the connections on the pump ports and take care to prevent any system debris from entering the pump via the connectors.

Wiring

- g Remove the four retaining screws holding the PCB cover (**fig.5**). Lift the cover together with the variable speed control from the pump body.
- h The 3-core cable from the mains electricity supply can now be connected to the terminal block situated on the PCB (**fig.6**). The size of cable to use must be a minimum of 0.75mm.

Ensure the terminal block screws are fully tightened and that no cable insulation is trapped under the screws.

Note: When connecting the earth cable to the earth post, take care NOT to overtighten the securing nut.

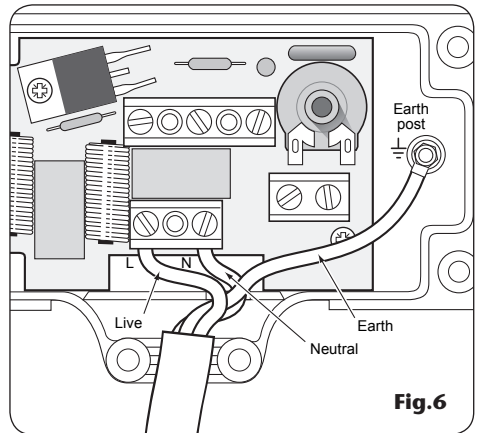
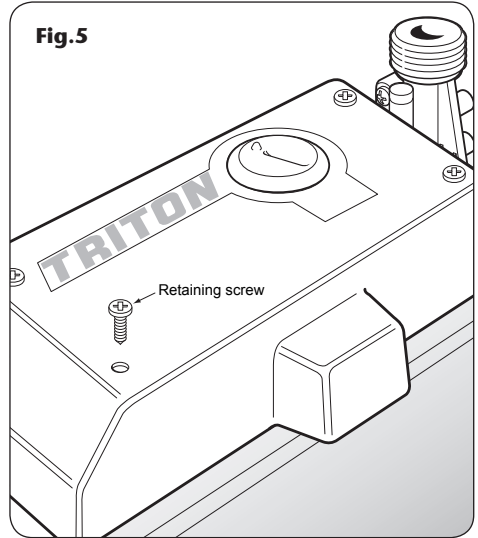

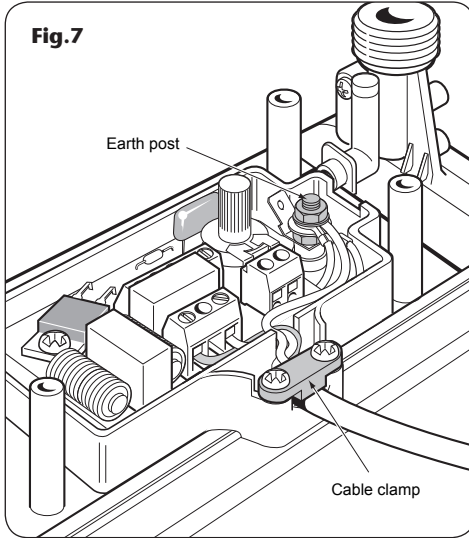

IMPORTANT: Remove only the minimum amount of conductor insulation when wiring to the terminal block.

The cable clamp must be used to secure the cable (**fig.7**).

Note: Before replacing the cover, ensure the potentiometer is rotated fully clockwise (**fig.8**) until a 'stop' is felt. Then ensure the speed control is positioned to '3' on the cover (**fig.9**).

Replace the PCB cover and variable speed control. Should the control knob have been detached from the cover, ensure the 'O' ring (**fig.10**) is correctly seated before replacing the control knob.

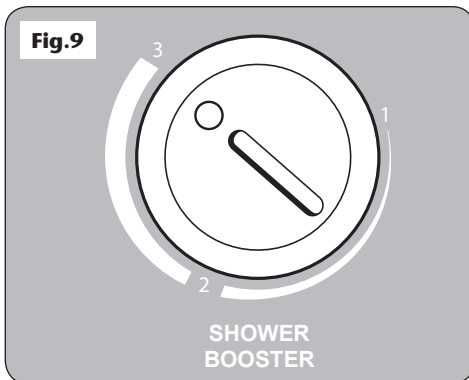
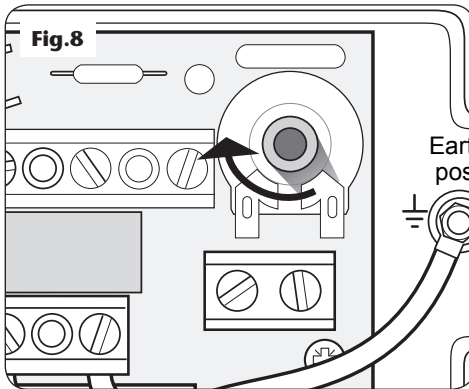

WARNING!

Installation of the pump will break the earth continuity of the pipework installation. It is important that the earth be restored by cross bonding the pipework, to conform with current IEE regulations.

This appliance is not intended for use by persons (including children) with reduced physical, sensory or mental capabilities, or lack of experience and knowledge, unless they have been given supervision or instruction concerning use of the appliance by a person responsible for their safety. Children should be supervised to ensure that they do not play with the appliance.

VARIABLE SPEED CONTROL

The variable speed control (**fig.11**) can be adjusted to select the optimum performance of the pump to suit personal preferences.

COMMISSIONING

Before the first operation of the shower pump, it is necessary to flush out any system debris from the installation. This operation must be carried out with the pump isolated from the electricity supply, and with the pump feed pipework from the cistern and cylinder directed to waste by connecting a suitable length of hose.

Procedure

- 1 Ensure the isolating valves from the cistern and cylinder are closed.
- 2 Turn on the mains water supply to the storage cistern and allow the cylinder and system to fill.
- 3 Open both isolating valves and flush through thoroughly.
- 4 Allow water to flow to waste for two or three minutes to ensure any installation debris and air is completely flushed from the system.
- 5 Check the system pipework for leaks.
- 6 Close both isolating valves. Remove the waste hoses and connect the cistern supply pipework and cylinder pipework to the pump inlet flexible push-in connectors.
- 7 Remove the sprayhead from the mixer valve hose and direct the hose to waste.
- 8 Open the mixer valve fully and then re-open both isolating valves.
- 9 Allow water to flow under gravity from the hose for a few minutes.
- 10 Stop the flow at the mixer valve.
- 11 Switch on the mains electricity supply to the shower pump.
- 12 Open the mixer valve. The pump will operate and water will flow. Allow water to flow to waste for two or three minutes.
- 13 Check system pipework again for leaks.
- 14 Turn off the mixer valve – the pump will switch off and the water will cease to flow. Replace the sprayhead onto the shower hose.

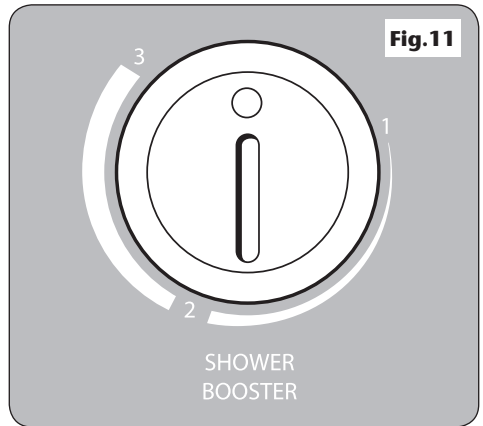
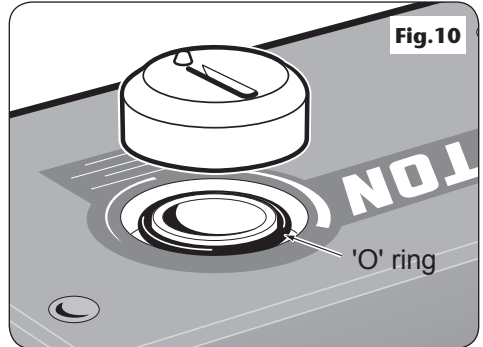

15 Switch off the electric supply to the pump and eliminate any leaks.

Note: If care has been taken to prevent any obvious debris entering the system, the above procedure should be adequate for normal operating conditions of the pump and shower. However, it may be advisable to also clean the filters in the inlet ports of the pump as an extra precaution.

SPARE PARTS

<i>Ref</i>	<i>Description</i>	<i>Part No.</i>
1	Pump assembly	T550i00M
2	Cover	7052286
3	Impeller housing	7051544
4	Pump inlet	7051543
5	Speed control knob	7051552
6	End cap	7052310
7	PCB assembly	7072314
8	Flow switch assembly	82300700
9	Flexible connector inlet c/w filter	22004500
10	Flexible connector	22004510

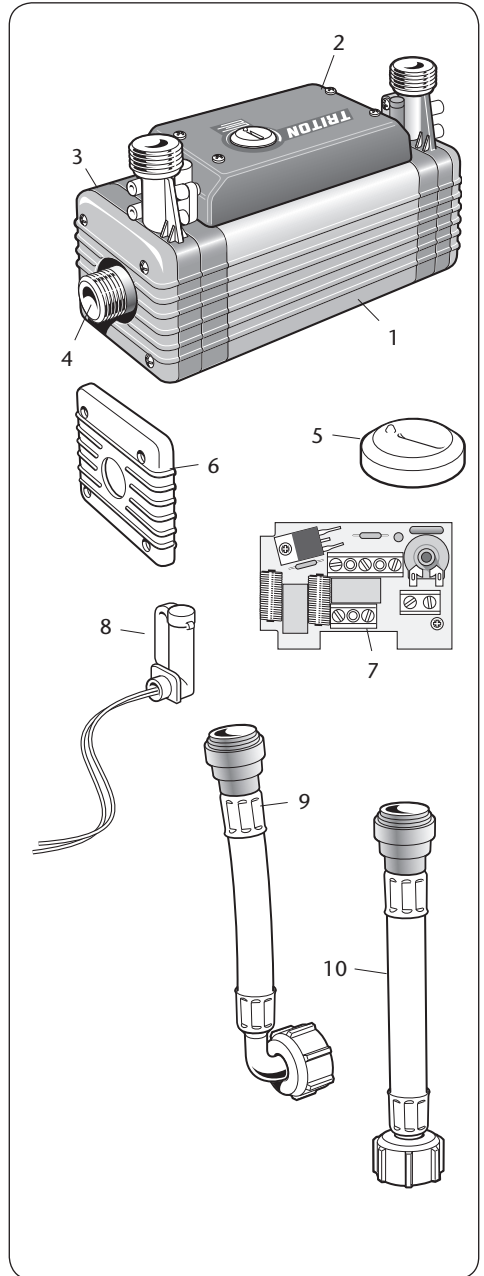

FAULT FINDING

Problem/symptom	Cause	Action/cure
1 Pump motor does not operate.	1.1 Pump motor thermal overload protection activated.	1.1.1 Allow the pump motor to cool and automatically reset. 1.1.2 Check the pump is adequately ventilated.
	1.2 Mains electricity supply fault.	1.2.1 Blown fuse. Check supply, and renew or reset fuse. If it fails again, contact Customer Service. 1.2.2 Power cut? Check other appliances and if necessary contact local Electricity Company.
	1.3 Loose wiring connections.	1.3.1 Check all connections and secure where necessary.
	1.4 Insufficient flow to operate flow switch.	1.4.1 Check isolating valve is fully open. 1.4.2 Check head of water. 1.4.3 Ensure inlet filter is clean.
	1.5 Faulty flow switch.	1.5.1 Replace switch. Contact Triton Customer Service for advice.
	1.6 Failed pump motor.	1.6.1 Replace the pump unit. Contact Triton Customer Service.
2 Poor or no water flow.	2.1 Pump motor not running.	2.1.1 See causes 1.1, 1.2, 1.3, 1.4, 1.5, and 1.6
	2.2 Pump or shower unit frozen.	2.2.1 Check for evidence of freezing. Contact Triton Customer Service for advice.
	2.3 Water turned off.	2.3.1 Check isolation valves and water supply.
	2.4 No water in cold storage cistern.	2.4.1 See 2.3.1
	2.5 System blockage.	2.5.1 Isolate supplies and inspect inlet filter, pump outlet and sprayhead.
	2.6 Blocked sprayhead on shower unit.	2.6.1 Clean the sprayhead. Refer to separate instructions.
	2.7 Blocked filter.	2.7.1 Clean filter.
3 Pump does not switch off.	3.1 Faulty flow switches.	3.1.1 Replace flow switches. Isolate electric supply to pump. Contact Triton Customer Service for advice.

Any maintenance or repair to the pump MUST be carried out by a suitably competent person.



Service Policy

In the event of a product fault or complaint occurring, the following procedure should be followed:

- 1 Telephone Customer Service on 0870 067 3333 (0845 762 6591 in Scotland and in Northern Ireland), having available, your details including post code, the model number and power rating of the product, together with the date of purchase.
- 2 Based on information given over the telephone, a Triton Customer Service Advisor will attempt to diagnose the fault and confirm whether a site visit from a qualified service engineer is required.
- 3 All products attended to by a Triton service engineer must be installed in full accordance with the Triton installation guide applicable to the product. (Every product pack contains an installation guide, however, they can also be bought via our Customer Service Spares Department).
- 4 Our engineer will require local parking and if a permit is required this must be available to the engineer on arrival at the call.
- 5 It is essential that you or an appointed representative (who must be over 18 years of age) is present for the duration of the service engineer's visit. If the product is in guarantee you must produce proof of purchase.
- 6 Where a call under the terms of guarantee has been booked and the failure is not product related (i.e. scaling and furring, incorrect water pressure, pressure relief device operation or electrical/plumbing installation fault) a charge will be made. A charge will also be issued if nobody is at home when the service engineer calls or adequate parking/permit is not available.
- 7 If the product is no longer covered by the guarantee an up front fixed fee will be charged before the site visit.
- 8 Should proof of purchase not be available on an "in-guarantee" call, or should the service engineer find that the product is no longer under guarantee, the engineer will charge the same fixed price and the customer will be expected to pay the engineer before he leaves. If payment is not made on the day an administration charge will be added to the fixed charge.
- 9 If a debt is outstanding from a previous visit, or from any other Triton purchase, Triton reserves the right to withhold service until the debt has been settled.
- 10 Triton takes the health, safety and wellbeing of its employees very seriously and expects customers to treat all staff members with respect. Should any employee feel threatened or receive abuse, either verbally or physically, Triton reserves the right to withhold service and will support the employee with a legal prosecution.

Replacement Parts Policy

Availability: It is the policy of the manufacturer to maintain parts availability for the duration of production and a period of five years thereafter, in accordance with industry standards.

Spare parts are available via our website, www.tritonshowers.co.uk, or by telephoning Triton Customer Service Spares Department. Payment should be made by credit/debit card (excluding American Express or Diners Card).

Payment can also be made by pre-payment of a pro forma invoice by cheque or money order.

Triton Showers
Triton Road
Nuneaton
Warwickshire CV11 4NR

Triton is a division of Norcross Group (Holdings) Limited

TRITON STANDARD GUARANTEE

Triton guarantee this product against all mechanical defects arising from faulty workmanship or materials for a period of one year for domestic use only, from the date of purchase, provided that it has been installed by a competent person in full accordance with the fitting instructions.

Any part found to be defective during this guarantee period we undertake to repair or replace at our option without charge so long as it has been properly maintained and operated in accordance with the operating instructions, and has not been subject to misuse or damage.

This product must not be taken apart, modified or repaired except by a person authorised by Triton. This guarantee applies only to products installed within the United Kingdom and does not apply to products used commercially. This guarantee does not affect your statutory rights.

What is not covered:

- 1 Breakdown due to: **a)** use other than domestic use by you or your resident family; **b)** wilful act or neglect; **c)** any malfunction resulting from the incorrect use or quality of water or incorrect setting of controls; **d)** faulty installation.
- 2 Repair costs for damage caused by foreign objects or substances.
- 3 Total loss of the product due to non-availability of parts.
- 4 Compensation for loss of use of the product or consequential loss of any kind.
- 5 Call out charges where no fault has been found with the appliance.
- 6 The cost of repair or replacement of showerheads, hoses, riser rails and/or wall brackets or any other accessories installed at the same time.
- 7 The cost of routine maintenance, adjustments, overhaul modifications or loss or damage arising therefrom, including the cost of repairing damage, breakdown, malfunction caused by corrosion, furring, pipe scaling, limescale, system debris or frost.

Customer Service: ☎ 0870 067 3333

Scottish and Northern Ireland

Customer Service: ☎ 0845 762 6591

Trade Installer Hotline: ☎ 0870 067 3767

Fax: 0870 067 3334

www.tritonshowers.co.uk

E mail: technical@tritonshowers.co.uk