

**T30i
electric
handwash**



**Installation and
operating
instructions**



INSTALLERS PLEASE NOTE THESE INSTRUCTIONS ARE TO BE LEFT WITH THE USER

CONTENTS	Page
Important safety information	1
Introduction	2
Specification	2
Advice to users	2
Key to main components	3
Electrical requirements	4 – 5
Water requirements	6
Siting of the unit	7
Fitting the unit to the wall	8 – 9
Plumbing connections	10
Electrical connections	11
Replacing the cover	12
Swivel arm fitting	12
Commissioning	13
Operating the unit	14
Operating functions	15
Cleaning	16
Spare parts	17
Fault finding	18 – 19
Guarantee, service policy, etc.	rear cover

To check the product suitability for commercial and multiple installations, please contact Triton's specification advisory service before installation.

Telephone: 0870 067 3767

Facsimile: 0870 067 3334

E mail: technical@tritonshowers.co.uk

PLEASE READ THIS IMPORTANT SAFETY INFORMATION

- ◆ Products manufactured by Triton are safe and without risk provided they are installed, used and maintained in good working order in accordance with our instructions and recommendations.
- ◆ **WARNING: DO NOT operate unit if it is frozen, or suspected of being frozen. It must thaw out before using.**
- ◆ DO NOT operate the unit if water ceases to flow during use or if water has entered inside the unit because of an incorrectly fitted cover.
- ◆ **WARNING: If restarting the handwash immediately after stopping, be aware that a slug of hot water will be expelled for the first few seconds.**

1 General

- 1.1** Isolate the electrical and water supplies before removing the cover.
- 1.2** Read all of these instructions and retain them for later use.
- 1.3** DO NOT take risks with plumbing or electrical equipment.
- 1.4** Isolate electrical and water supplies BEFORE proceeding with the installation.
- 1.5** The unit must be mounted onto the finished wall surface (on top of the tiles). DO NOT tile up to unit after fixing to wall.
- 1.6** Contact Customer Service (*see back page*), if any of the following occur:
- a) If it is intended to operate the unit at pressures above the maximum or below the minimum stated.
 - b) If the unit shows a distinct change in performance.
 - c) If the unit is frozen.
- 1.7** If it is intended to operate the handwash in areas of hard water (above 200 ppm temporary hardness), a scale inhibitor may have to be fitted. For advice on the Triton Scale Inhibitor, contact Customer Service.
- 1.8** The spray rings must be cleaned regularly with descaler to remove scale and debris, otherwise restrictions to the flow on the outlet of the unit will result in higher temperatures and could also cause the Pressure Relief Device (PRD) in the unit to operate.
- 1.9** This product is not suitable for mounting into steam rooms or steam cubicles.

2 Plumbing

- 2.1** The plumbing installation must comply with Water Regulations/Byelaws, Building Regulations or any particular regulations as specified by Local Water Company or Water Undertakers and in accordance with BS 6700.
- 2.2** The supply pipe must be flushed to clear debris before connecting to the handwash.
- 2.3** DO NOT solder pipes or fittings within

300mm of the appliance, as heat transfer can damage components.

- 2.4** DO NOT fit any form of outlet flow control as the outlet acts as a vent for the heater can.
- 2.5** DO NOT use excessive force when making connections to the sprayhead, finger tight is sufficient.
- 2.6** All plumbing connections MUST be completed BEFORE making the electrical connections.

3 Electrical

- 3.1** The installation must comply with BS 7671 'Requirements for electrical installations' (IEE wiring regulations) or any particular regulations as specified by the local Electrical Supply Company.
- 3.2** This appliance MUST be earthed.
- 3.3** In accordance with 'The Plugs and Sockets etc. (Safety) Regulations 1994', this appliance is intended to be permanently connected to the fixed wiring of the electrical mains system.
- 3.4** Ensure all electrical connections are tight to prevent overheating.
- 3.5** Fuses do not give personal protection against electric shock.
- 3.6** *To enhance electrical safety* a 30mA residual current device (RCD) should be installed in all UK electric circuits. This may be part of the consumer unit or a separate unit.
- 3.7** Switch off immediately at isolating switch if water ceases to flow during use.
- 3.8** Other electrical equipment i.e. extractor fans, pumps must not be connected to the circuits within the unit.
- 3.9** Switch off at isolating switch when not in use. This is a safety procedure recommended with all electrical appliances.
- 3.10** As with all electrical appliances it is recommended to have the unit and installation checked at least every two years by a competent electrician to ensure there is no deterioration due to age and usage.

INTRODUCTION

This book contains all the necessary fitting and operating instructions for your Triton T30i electric handwash unit. Please read them carefully.

The installation must be carried out by a suitably qualified person and in the sequence of this instruction book.

Care taken during the installation will ensure a long, trouble-free life from your handwash.

SPECIFICATIONS

Electrical

Nominal power rating at 240V	Nominal power rating at 230V
3kW – 13A	2.7kW – 13A
7kW – 30A	6.5kW – 30A

Water

Inlet connection – 15mm diameter.

Outlet connection – ½" BSP male thread.

Entry Points

Water – bottom.

Cable – top, bottom or back.

Materials

Backplate, cover, control knobs – ABS.

Elements – Minerally insulated corrosion resistant metal sheathing.

Dimensions

Height – 173 mm

Width – 200 mm

Depth – 108 mm

Standards and Approvals

Splashproof rating IPX4.

Complies with the requirements of current British and European safety standards for household and similar electrical appliances.

Complies with requirements of the British Electrotechnical Approvals Board (BEAB).

Meets with Compliance with European Community Directives (CE).

ADVICE TO USERS

The following points will help you understand how the handwash operates:

a. The electric heating elements operate at a constant rate. It is the flow rate of the water passing through the heater can which determines the water temperature at any given setting. (The slower the flow, the hotter the water becomes and the faster the flow, the cooler the water).

b. During winter, mains water supply will be cooler than in summer. Therefore the water temperature of the unit will vary between seasons on any one setting of the temperature control, e.g. if you have chosen setting number 6 as your preferred handwash temperature in the summer, you may have to increase that number during winter by adjusting the temperature control anti-clockwise (which in effect slows the water flow).

c. The stabiliser valve minimises variations in water temperature during mains water pressure changes. If changes in water temperature are experienced during normal use, it will most likely be caused by the water pressure falling near to or below the minimum level. The drop in pressure may be due to water being drawn off at other points whilst the unit is in use. If the pressure drops appreciably below the minimum, the heating elements will automatically cut out.

DO NOT place items such as soap or shampoo bottles on top of the unit. Liquid could seep through the joint between the cover and backplate, and possibly damage the sealing rubber.

If water becomes too hot and you cannot obtain cooler water, first check that the sprayhead is not blocked.

Replacement parts can be ordered from Customer Service. See 'spare parts' for details and part numbers.

KEY TO MAIN COMPONENTS

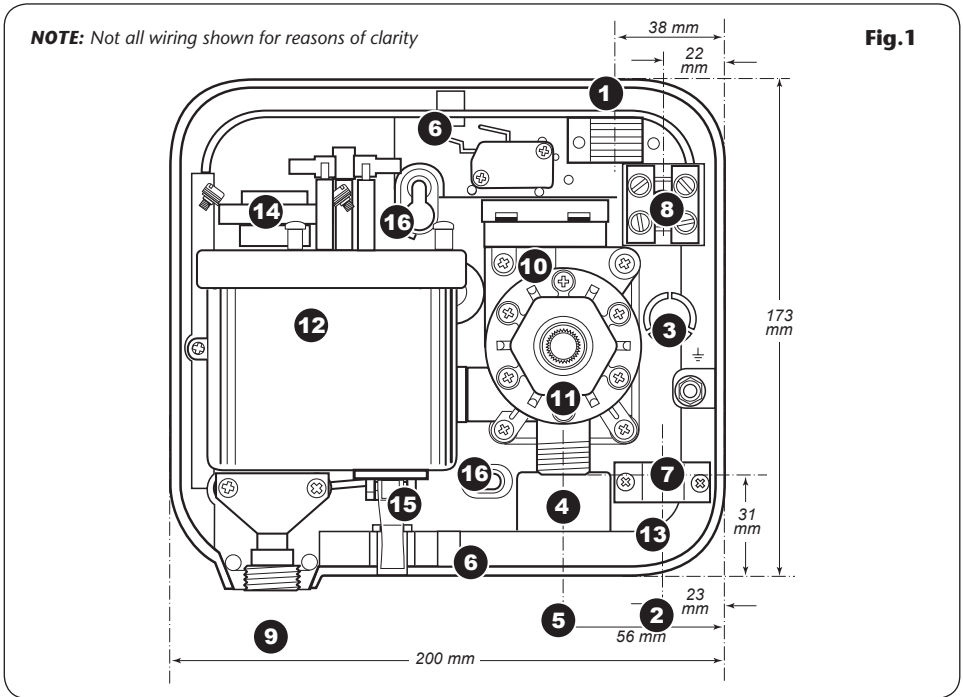

Inside unit – fig.1

1. Top cable entry
2. Bottom cable entry
3. Rear cable entry
4. Water inlet
5. Pipe entry
6. Cover screw fixing
7. Earth connection
8. Terminal block
9. Outlet pipe
10. Pressure switch
11. Stabilising valve
12. Can and element assembly
13. Cable clamp
14. Thermal cut-out
15. Pressure relief device (PRD)
16. Wall screw fixings

Pack contents

- Handwash unit
- 200mm swivel arm
- Fixing screws and plugs
- Instructions, guarantee, etc.

ELECTRICAL REQUIREMENTS

WARNING! THIS APPLIANCE MUST BE EARTHED

The installation, supply cable and circuit protection must conform with BS7671 (IEE wiring regulations) and be sufficient for the amperage required.

The following notes are for guidance only:

- 1** The unit must only be connected to a 230-240V ac supply.
- 1.1** The electrical rating of the unit is shown on the rating label (**fig.2**) within the unit.

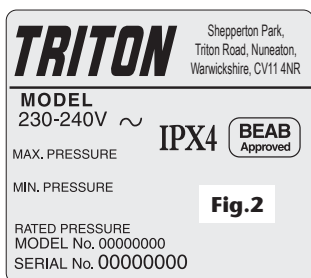
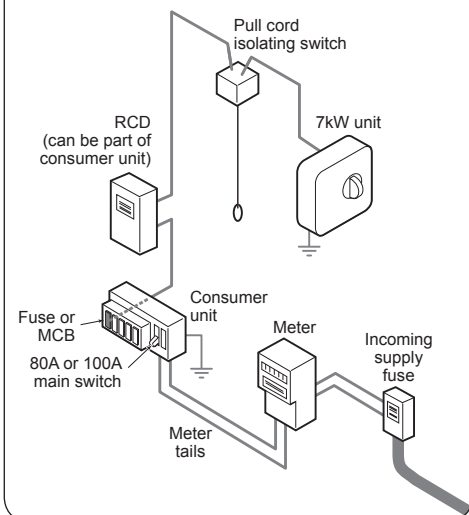

Fig.3 schematic of installation circuit
(7kW unit only)



- 2** Before making any sort of electrical connection within the installation, ensure that no terminal is live. If in any doubt, switch off the whole installation at the consumer unit.
- 3** The 7kW rated handwash must be connected to its own independent electrical circuit. IT MUST NOT be connected to a ring main, spur, socket outlet, lighting circuit or cooker circuit.

The 3kW rated handwash can be connected to a ring main via a 13A fused spur.

- 3.1** The electrical supply must be adequate for the loading of the unit and existing circuits.
- 4** Check your consumer unit (main fuse box) has a main switch rating of 80A or above and that it has a spare fuse way which will take the fuse or MCB necessary for the handwash (**fig.3**).
- 4.1** If your consumer unit has a rating below 80A or if there is no spare fuse way, then the installation will not be straight forward and may require a new consumer unit serving the house or just the handwash/shower.
- 4.2** You will need to contact the local electricity company. They will check the circuit and carry out what is necessary. They will also check the main bonding.
- 5** The earth continuity conductor of the electrical installation must be effectively connected electrically to all exposed metal parts of other appliances and services in the room in which the handwash is to be installed, to conform to current IEE regulations.
- 5.1** All exposed metallic parts in the bathroom must be bonded together using a cable of

Table A

CIRCUIT PROTECTION		
unit rating	MCB	cartridge fuse
3.0kW	–	13A
7.0kW	30/32A	30A

at least 4mm² cross sectional area. These parts include metal baths, radiators, water pipes, taps and waste fittings.

- 6** For close circuit protection DO NOT use a rewirable fuse. Instead use a suitably rated miniature circuit breaker (MCB) or cartridge fuse (**see table A**).
- 6.1** In the interest of electrical safety a 30mA residual current device (RCD) should be installed in all UK electric circuits. This may be part of the consumer unit or a separate unit.
- 7** A 45 amp double pole isolating switch with a minimum contact gap of 3mm in both poles must be incorporated in the circuit of the 7kW unit.
- 7.1** It must have a mechanical indicator showing when the switch is in the OFF position.
- 7.2** The wiring must be connected to that switch without the use of a plug or socket outlet.
- 7.3** The switch must be readily accessible and clearly identifiable, but out of reach of a person using the unit.
- 7.4** If the isolating switch is to be fitted in a bathroom, then it must be a cord operated type and should be placed so that it is not possible to touch the switch body when using the handwash.
- 7.5** Preferably it should be outside the handwash area and be readily accessible in order to switch off after using the unit.
- 8** The current carrying capacity of the cable must be at least that of the handwash unit circuit protection (**see table B**).
- 8.1** To obtain full advantage of the power provided by the handwash, use the shortest cable route possible from the consumer unit to the handwash.
- 8.2** It is also necessary to satisfy the disconnection time and thermal constraints which mean that for any given combination of current demand, voltage drop and cable size, there is a maximum permissible circuit length.
- 9** The handwash circuit should be separated from other circuits by at least twice the diameter of the cable or conduit.
- 9.1** The current rating will be reduced if the cabling is bunched with others, surrounded by thermal loft or wall insulation or placed in areas where the ambient temperature is above 30°C. Under these conditions, derating factors apply and it is necessary to select a larger cable size.
- 9.2** In any event, it is essential that individual site conditions are assessed by a competent electrician in order to determine correct cable size and permissible circuit length.

Table B

**Twin and earth PVC insulated cable
CURRENT CARRYING CAPACITY**

installed in an insulated wall	in conduit or trunking	clipped direct or buried in a non insulated wall
1.5mm ² 14A	1.5mm ² 16A	1.5mm ² 19A
2.5mm ² 18A	2.5mm ² 23A	2.5mm ² 27A
6mm ² 32A	6mm ² 38A	6mm ² 46A

Note: Cable selection is dependent on derating factors

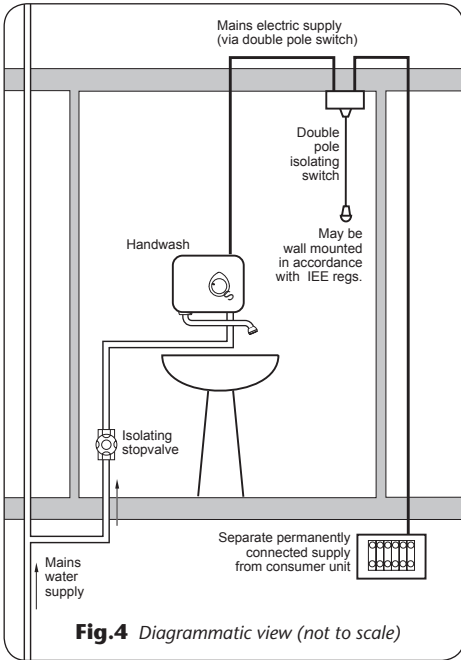

WATER REQUIREMENTS

The installation must be in accordance with Water Regulations and Bylaws.

To guarantee activation of the heating elements, the unit must be connected to a mains water supply with a minimum running pressure of 100kPa (1.0 bar) at a minimum flow rate of eight litres/minute and a maximum static pressure of 1000kPa (10 bar).

Note: If the stated flow rates are not available, it may not be possible to achieve optimum performance from the unit throughout the year.

The water supply can be taken from a cold water storage cistern provided there is a minimum head of ten metres above the unit. It must be an independent supply to the handwash unit only.

If it is intended to operate the unit at pressures above the maximum or below the minimum stated, contact Customer Service for advice.

Fig.4 shows a typical system layout for the 7kW rated handwash unit.

DO NOT use jointing compounds on any pipe fittings for the installation.

SITING OF THE UNIT

IMPORTANT: For ease of servicing, the unit must always be mounted on the surface of tiled walls. NEVER tile up to the unit.

Refer to **fig.4** for correct siting of the handwash unit.

Pressure relief safety device

A pressure relief device (PRD) is designed into the handwash unit which complies with European standards. The PRD provides a level of appliance protection should an excessive build up of pressure occur within the unit.

DO NOT operate the handwash with damaged or blocked spray rings which can cause the PRD to operate.

When commissioning, the sprayhead must be removed from the swivel arm or hose, while at the same time the temperature control must be at the minimum flow position. Failure to follow this procedure may also cause the PRD to operate.

Make sure the handwash is positioned over a sink or basin, because if the PRD operates, then water will eject from the bottom of the unit.

Should this happen, turn off the electricity and water supplies to the unit at the isolating switch and stop valve.

Contact Customer Service for advice on replacing the PRD.

WARNING!

The unit MUST NOT be positioned where it will be subjected to freezing conditions.

IMPORTANT: The unit must be mounted on a flat surface which covers the full width and length of the backplate. It is important that the wall surface is flat otherwise difficulty may be encountered when fitting the cover and subsequent operation of the unit may be impaired.

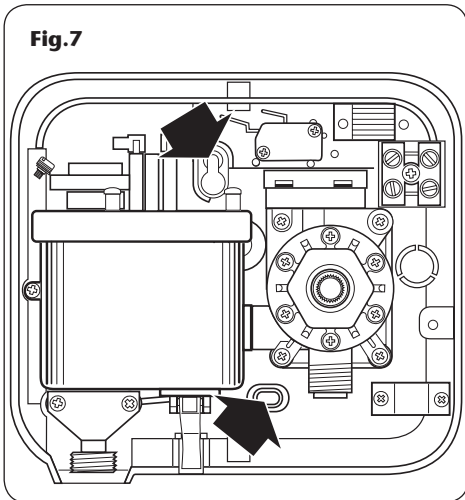
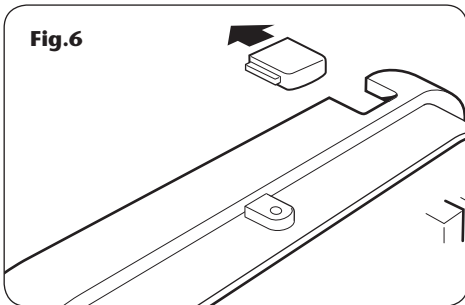
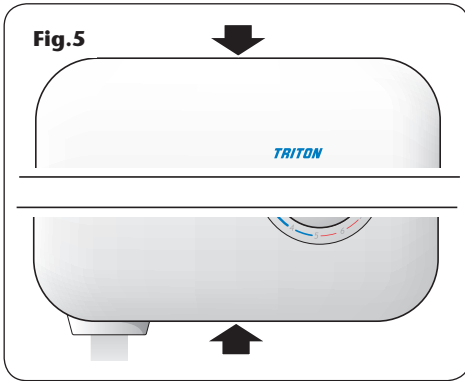

FITTING THE UNIT TO THE WALL

WARNING!

Check there are no hidden cables or pipes before drilling holes for wall plugs. Use great care when using power tools near water. The use of a residual current device (RCD) is recommended.

Procedure

Unscrew the top and bottom retaining screws (**fig.5**) and lift the cover from the backplate.

Note: The control knob is an integral part of the cover — DO NOT attempt to remove it. Entry position for the mains water is at the bottom only.

Entry position for the mains water is bottom only, and entry for electrical supplies are at the top, bottom or back of the unit. If top or bottom entry position is chosen, the relevant cut-out in the backplate must be removed (**fig.6**).

Electrical supplies are at the top, bottom, or at the rear of the unit. If top or bottom entry position is chosen, the relevant cut-out in the backplate must be removed.

Position the unit vertically and using the backplate as a template, mark the two fixing holes (**fig.7**).

Drill and plug to suit the fixing screws supplied. *(The wall plugs provided are suitable for most brick walls — use an appropriate masonry drill, but if the wall is plasterboard or a soft building block, you must use suitable wall plugs and an appropriate drill bit).*

Screw top fixing screw into position leaving the base of the screw head protruding 6mm out from the wall. Hook the backplate over the top screw and fit the bottom fixing screw into position.

DO NOT fully tighten the screws at this stage, as the fixing holes are elongated to allow for out of square adjustment after the plumbing connections have been completed.

IMPORTANT: Using a suitable sealant, always seal around the incoming pipework to prevent water entering the wall.

WARNING!

The outlet of the unit acts as a vent and must not be connected to any tap or fitting not recommended by Triton Plc.

PLUMBING CONNECTIONS**Plumbing to be carried out before wiring.**

DO NOT use jointing compounds on any pipe fittings for the installation.

DO NOT use soldered fittings near the unit as heat can transfer along the pipework and can damage components.

Note: An additional stop valve (complying with Water Regulations/Bylaws) MUST be fitted in the mains water supply to the unit as an independent means of isolating the water supply should maintenance or servicing be necessary.

IMPORTANT: Before completing the connection of the water supply to the inlet of the unit, flush out the pipework to remove all swarf and system debris. To do this, connect a hose to the pipework and turn on the mains water supply long enough to clear the debris to waste.

Procedure

Turn off the water supply either at the mains stop valve or the isolating stop valve.

Connect the mains water supply to the inlet of the unit via 15mm pipe using the nut and olive supplied (**fig.8**). Make sure the filter is inserted in the pipe before connection. This helps to prevent ingress of debris.

Check the backplate is square on the wall and then tighten the two retaining screws which hold it to the wall.

Turn on the mains water supply and check for leaks in the pipework connection to the unit.

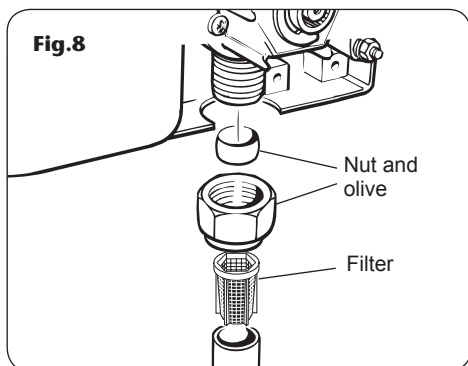

ELECTRICAL CONNECTIONS

SWITCH OFF THE ELECTRICITY SUPPLY AT THE MAINS.

Fig.9 shows the 3kW unit and 7kW unit schematic wiring diagrams.

The cable can be surface clipped, hidden or via 20mm conduit. For the 3kW handwash unit the minimum cable size will be 1.5mm² and for the 7kW unit the minimum will be 6mm².

Note: The supply cable earth conductor must be sleeved. The outer sheath of the supply cable must be stripped back to the minimum.

Note: For top cable entry, remove sufficient outer sheath to assist routing beneath and looping back into the terminal block. DO NOT however, remove so much outer sheath that there is insufficient to be held at the clamp. The cable MUST be clamped on the outer sheath. The cable clamp (**fig.10**) is suitable for up to 4mm² cable or can be reversed for use with up to 10mm² cable.

Note: Conduit entry can only be from rear. Route the cable into the unit and connect to the terminal block (**fig.10**) as follows:

Earth cable to terminal marked **E** 

Neutral cable to terminal marked **N**

Live cable to terminal marked **L**

IMPORTANT: Fully tighten the terminal block screws and ensure that no cable insulation is trapped under the screws. Loose connections can result in cable overheating.

The use of connections within the unit, or other points in the circuit, to supply power to other equipment i.e. extractor fans, pumps etc. will invalidate the guarantee.

DO NOT switch on the electricity supply until the cover has been fitted.

1. Terminal block
2. Thermal cut-out
3. Microswitch
4. Element

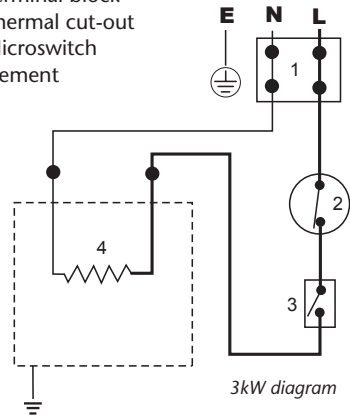
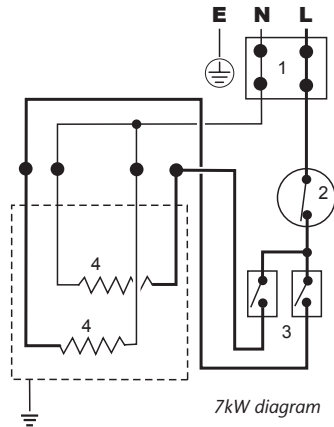
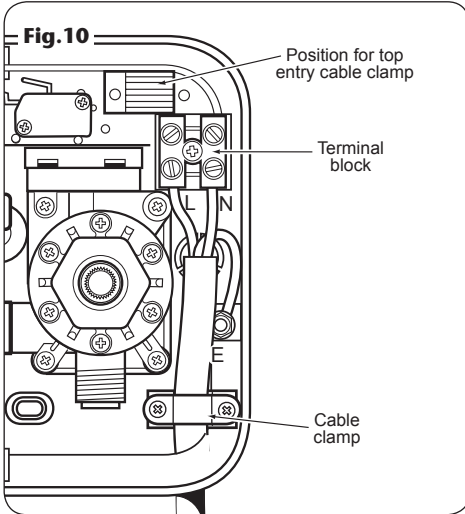



Fig.9





REPLACING THE COVER

To ensure that the temperature control is correctly positioned on the stabiliser valve, temporarily place the cover in position so that the splines engage and rotate the temperature control fully clockwise.

Remove the cover and position the temperature control so that it points at the  position (**fig.11**).

Replace the cover squarely to the backplate and guide into position so that the control locates correctly into the splined spindle. Should any difficulty arise, recheck the points above.

Secure the cover in position with the two retaining screws.

DO NOT switch on the electricity supply to the unit until the commissioning procedure has been carried out.

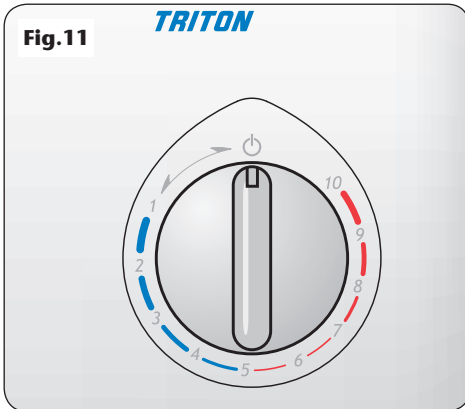

SWIVEL ARM FITTING

Screw the swivel arm connector onto the outlet pipe (**fig.12**). Ensure the sprayhead unit is securely screwed onto the end of the swivel arm.

Note: It is advisable to apply PTFE tape or silicon sealant to the threads of the outlet pipe prior to fitting the swivel arm in order to provide a watertight seal.

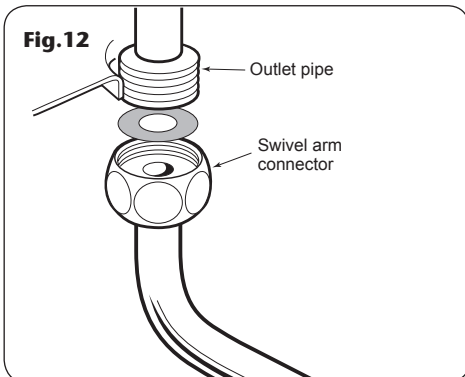

COMMISSIONING

WARNING!

Before normal operation of the handwash, it is essential the following commissioning procedure is completed correctly.

The first operation of the unit is intended to flush out any unit debris, and to ensure the heater unit contains water before the elements are switched on. The electricity must be switched OFF at the isolating switch.

This operation must have the swivel arm screwed to the outlet pipe but without the sprayhead attached to the arm.

Make sure the water supply is turned OFF at the isolating valve. Make sure the swivel arm is directed to waste.

Rotate the temperature control fully anti-clockwise to '10' – the minimum flow position (**fig.13**).

Note: Leaving the control at any position other than '10' may cause the PRD to operate.

Turn the water supply back ON at the isolating valve.

Wait until water starts to flow from the swivel arm then rotate control fully clockwise to '1' – the maximum flow position (**fig.14**).

It will take about thirty seconds for a smooth flow of water to be obtained when air and any debris is being dispersed from the unit. When a smooth flow of water is obtained, rotate the control from '1' to '10' and back again several times to release any trapped air.

Once flushing out has been completed, stop the water flow by rotating the control clockwise to the  position.

Refit the sprayhead to the swivel arm. Switch on the electricity supply to the handwash at the isolating switch.

The unit is now ready for normal operation.

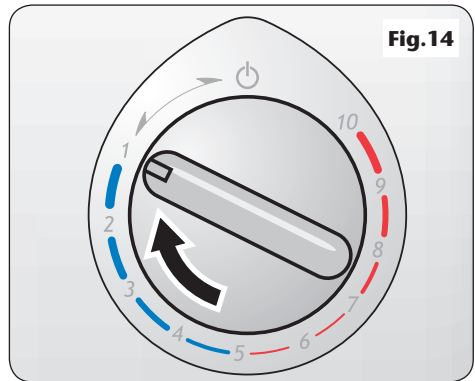
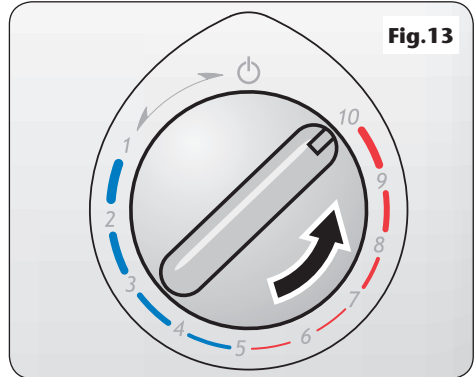

Fig.15

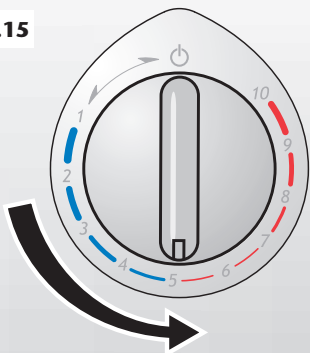

Fig.16

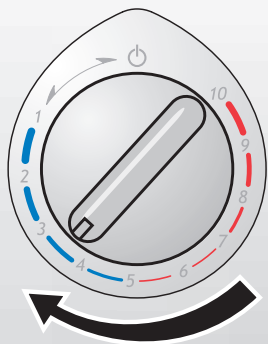
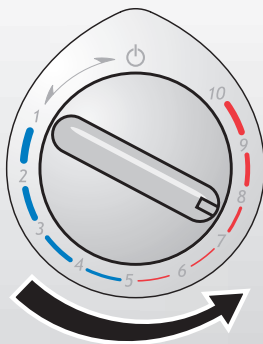

Fig.17



Note: In normal use, it is in order to leave the water supply permanently on to the shower unit, but as with most electrical appliances, **the unit must be switched off at the isolating switch when not in use.**

OPERATING THE UNIT

WARNING!

Before normal operation of the handwash, it is essential that the commissioning procedure has been completed correctly.

To start the handwash unit

Turn the temperature control anti-clockwise and the water will begin to flow.

The flow of water is controlled by the combined start/stop temperature control.

To obtain warm water turn the control slowly anti-clockwise to the mid position (**fig.15**).

If the water is too hot, turn the control slowly clockwise towards the lower numbers (**fig.16**).

If the water is too cool, turn the control slowly anti-clockwise towards the higher numbers (**fig.17**).

Note: There will always be a short time delay between selecting a flow rate and reaching the stable temperature for that flow rate.

To stop the handwash unit

WARNING!

If restarting immediately after stopping, be aware that a slug of hot water will be expelled for the first few seconds.

Turn the temperature control fully clockwise to the  position, and water will cease to flow.

OPERATING FUNCTIONS

Low water pressure cut-out

If the water pressure falls below the minimum required for correct operation of the unit, power will be switched off to the heating elements preventing any maintained temperature rises (water will continue to flow).

Power will automatically be restored when adequate water pressure returns.

Safety cut-out

The unit is fitted with a non-resettable thermal cut-out safety device. In the event of abnormal operation which could cause unsafe temperatures within the unit, the device will disconnect the heating elements. It will require a visit from a qualified engineer to determine the nature of the fault and replace the safety device, once the unit has been repaired.

WARNING!

After any servicing of the mains water supply, always make sure the unit is started on COLD in order to purge any air in the pipework.

WARNING!

DO NOT use 'powerful' abrasive or solvent cleaning fluids when cleaning the shower as they may damage the plastic fittings.

CLEANING

Before cleaning, turn off the unit at the isolation switch to avoid the handwash being accidentally switched on.

Cleaning the sprayhead and rings

The sprayhead is a critical part of the unit and has been designed to give the maximum performance.

IMPORTANT: Triton sprayheads ONLY to be used with this product.

In order to maintain the performance from the handwash, the spray rings should be cleaned at regular intervals to prevent build up of deposits from the water supply.

When first installed it may be required to clean the spray rings due to debris that may be left in the pipework after installation, especially if the commissioning procedure has not been carried out. Once this initial debris is cleared the frequency of cleaning will depend upon the type of water available.

Hard water areas may require cleaning once a week whereas soft water areas may only require cleaning every six months.

Note: Blocked spray rings can reduce the water flow to such an extent that it will cause the thermal cut-out or PRD to operate.

Procedure

Unscrew the complete sprayhead assembly from the swivel arm (**fig.18**). Remove the retaining screw and withdraw the spray rings (**fig.18**). Clean with a suitable brush, ensuring all traces of scale are removed from the spray ring grooves. Rinse in clean water and refit the assembly.

Note: The swivel arm has the option of being fitted with a trim only. If required, unscrew the sprayhead assembly and push the trim onto the threaded portion of the arm.

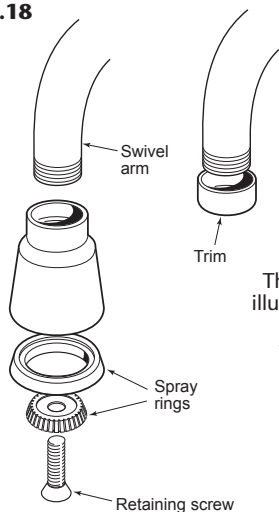
Fig.18

The sprayhead illustrated is the 3kW model. The 7kW has two serrated rings.

SPARE PARTS

Ref. Description	Part No.
1. Cover assembly	81200120
2. Heater can assembly	
3kW	84500010
7kW	84500020
3. Stabilising valve assembly	
3kW	82600730
7kW	82600720
4. Thermal cut-out	22010010
5. Terminal block & wires	82200110
6. Cable clamp	7050253
7. Pressure Relief Device (PRD)	83301330
8. Outlet pipe assembly	7051619
9. Swivel arm assembly	
3kW	82700080
7kW	82700090
10. Sprayhead assembly	83302080
– Switch and wire kit	
3kW	82301390
7kW	82301370
82301380	
– Filter	7052161

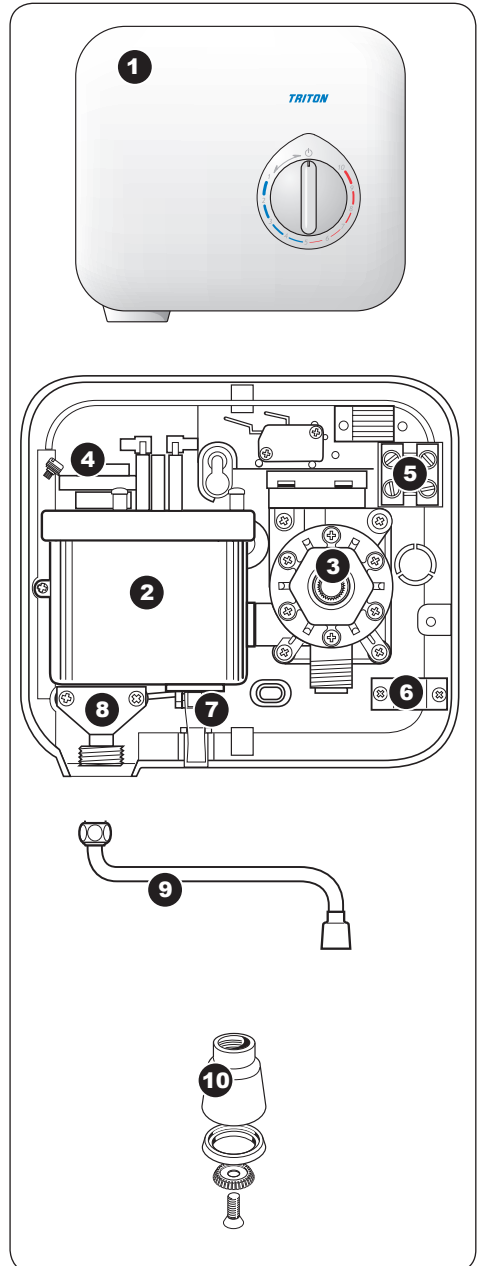

FAULT FINDING

IMPORTANT: Switch OFF the electricity at the mains supply and remove the circuit fuse before removing the cover from the handwash while attempting any fault finding inside the unit.

Problem/Symptom	Cause	Action/Cure
1 Unit inoperable, no water flow.	1.1 No mains water supply to unit. 1.2 Unit malfunction.	1.1.1 Check if isolating valves are fully open. Check if a blockage in inlet filter or in pipework. 1.2.1 Have unit checked. Ring Customer Service.
2 Water too hot.	2.1 Not enough water flowing through the unit. 2.2 Blockage in supply. 2.3 Increase in ambient water temperature.	2.1.1 Increase the flow rate. 2.1.2 Blocked sprayhead - clean or replace blocked spray rings. 2.2.1 Check if stop valves are fully open. Check if blockage in inlet filter. 2.3.1 Increase the flow rate.
3 Water temperature cycling hot/cold at intervals.	3.1 Heater cycling on thermal cut- out.	3.1.1 See 'Water too hot' causes 2.1, 2.2 and 2.3 and their appropriate action/cures. If it continues, contact Customer Service.
4 Water too cool or cold.	4.1 Too much flow. 4.2 Water pressure below minimum stated on rating label 4.3 Reduction in ambient water temperature. 4.4 Electrical malfunction. 4.5 Interrupted power supply.	4.1.1 Reduce the flow rate. 4.2.1 Is water supply mains or tank fed ? 4.2.2 If tank fed, replumb to mains water supply or see 4.2.4. 4.2.3 If mains fed, ensure that mains stop valve is fully open and that there are no other restrictions in the supply while the unit is in use, or see 4.2.4. 4.2.4 Fit a pump to give minimum pressure. Contact Customer Service for advice. 4.3.1 Reduce the flow rate. 4.4.1 Have unit checked by suitably qualified electrician or contact Triton Customer Service. 4.5.1 Blown fuse or circuit breaker. Check supply. Renew or reset fuse or circuit breaker. If it fails again, consult a qualified electrician. 4.5.2 Power cut. Check other appliances and if necessary, contact local Electricity Supply Company.

FAULT FINDING

Problem/Symptom	Cause	Action/Cure
5 Unit varies from normal temperature to cold during use.	5.1 Water pressure has dropped below minimum required	5.1.1 Wait until the water pressure resumes to normal.
6 Pressure relief device has operated (water ejected from PRD tube).	6.1 Blocked sprayhead.	6.1.1 Clean or replace blocked spray rings in the sprayhead and then fit new PRD.

Note: Identify cause of operation before fitting new PRD unit.
When fitting a new PRD, follow the commissioning procedure.

It is advised all electrical maintenance/repairs to the handwash unit should be carried out by a suitably qualified person.



Service Policy

In the event of a complaint occurring, the following procedure should be followed:

- 1 Telephone Customer Service on: 0870 067 3333 (0845 762 6591 in Scotland and in Northern Ireland), having available the model number and power rating of the product, together with the date of purchase.
- 2 Triton Customer Service will be able to confirm whether the fault can be rectified by either the provision of a replacement part or a site visit from a qualified Triton service engineer.
- 3 If a service call is required the unit must be fully installed for the call to be booked and the date confirmed. In order to speed up your request, please have your postcode available when booking a service call.
- 4 It is essential that you or an appointed representative (who must be a person of 18 years of age or more) is present during the service engineer's visit and receipt of purchase is shown.
- 5 A charge will be made in the event of an aborted service call by you but not by us, or where a call under the terms of guarantee has been booked and the failure is not product related (i.e. scaling and furring, incorrect water pressure, pressure relief device operation, electrical installation faults).
- 6 If the product is no longer covered by the guarantee, a charge will be made for the site visit and for any parts supplied.
- 7 Service charges are based on the account being settled when work is complete, the engineer will then request payment for the invoice. If this is not made to the service engineer or settled within ten working days, an administration charge will be added.

Replacement Parts Policy

Availability: It is the policy of Triton to maintain availability of parts for the current range of products for supply after the guarantee has expired. Stocks of spare parts will be maintained for the duration of the product's manufacture and for a period of five years thereafter.

In the event of a spare part not being available a substitute part will be supplied.

Payment: The following payment methods can be used to obtain spare parts:

- 1 By post, pre-payment of pro forma invoice by cheque or money order.
- 2 By telephone, quoting credit card (MasterCard or Visa) details.
- 3 By website order, www.tritonshowers.co.uk

Triton Showers
Triton Road
Nuneaton
Warwickshire CV11 4NR

Triton is a division of Norcross Group (Holdings) Limited

TRITON STANDARD GUARANTEE

Triton guarantee this product against all mechanical and electrical defects arising from faulty workmanship or materials for a period of one year for domestic use only, from the date of purchase, provided that it has been installed by a competent person in full accordance with the fitting instructions.

Any part found to be defective during this guarantee period we undertake to repair or replace at our option without charge so long as it has been properly maintained and operated in accordance with the operating instructions, and has not been subject to misuse or damage.

This product must not be taken apart, modified or repaired except by a person authorised by Triton. This guarantee applies only to products installed within the United Kingdom and does not apply to products used commercially. This guarantee does not affect your statutory rights.

What is not covered:

- 1 Breakdown due to: *a)* use other than domestic use by you or your resident family; *b)* wilful act or neglect; *c)* any malfunction resulting from the incorrect use or quality of electricity, gas or water or incorrect setting of controls; *d)* faulty installation.
- 2 Repair costs for damage caused by foreign objects or substances.
- 3 Total loss of the product due to non-availability of parts.
- 4 Compensation for loss of use of the product or consequential loss of any kind.
- 5 Call out charges where no fault has been found with the appliance.
- 6 The cost of repair or replacement of pressure relief devices, showerheads, hoses, riser rails and/or wall brackets, isolating switches, electrical cable, fuses and/or circuit breakers or any other accessories installed at the same time.
- 7 The cost of routine maintenance, adjustments, overhaul modifications or loss or damage arising therefrom, including the cost of repairing damage, breakdown, malfunction caused by corrosion, furring, pipe scaling, limescale, system debris or frost.

Customer Service: ☎ 0870 067 3333

**Scottish and Northern Ireland
Customer Service:** ☎ 0845 762 6591

Trade Installer Hotline: ☎ 0870 067 3767
Fax: 0870 067 3334

www.tritonshowers.co.uk

E mail: technical@tritonshowers.co.uk

Extended Warranty AVAILABLE NOW. Call 0870 067 3333 for more details.