

ASPIRANTE

FERVORE

Pillar basin taps



Installation and Operation Instructions

INSTALLERS PLEASE NOTE THESE INSTRUCTIONS ARE TO BE LEFT WITH THE USER

Fig.1

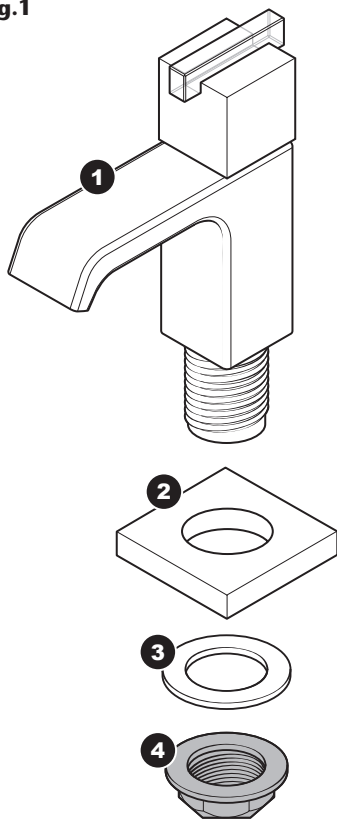

INTRODUCTION

This guide contains all the necessary fitting instructions for your Aspirante Fervore Pillar basin taps.

Please read this guide carefully before beginning your installation.

The tap installation must be carried out by a suitably competent person and in the sequence of the instruction book.

Care taken during the installation will provide long life and trouble free operation from your taps.

These taps are suitable for water pressures of 0.5 bar and above and should be fitted in accordance with Water Regulations.

DO NOT choose a position where the tap could become frozen.

Replacement parts can be ordered from Triton Customer Service (*see back page*).

COMPONENTS

The tap set comprises of the following (**fig.1**):

- 1.** Tap (2 off)
- 2.** Tap base (2 off)
- 3.** Sealing washer (2 off)
- 4.** Lock nuts (2 off)

Check that all parts are correct.

INSTALLATION

Fit the taps into the basin as shown in (**fig.2**).

Connect the hot and cold supplies to the taps using standard BSP ½" tap connectors.

LEAK TESTING

Switch on the supplies at the mains. Turn on the tap and test for leaks in the connections. Remedy if required.

Fig.2

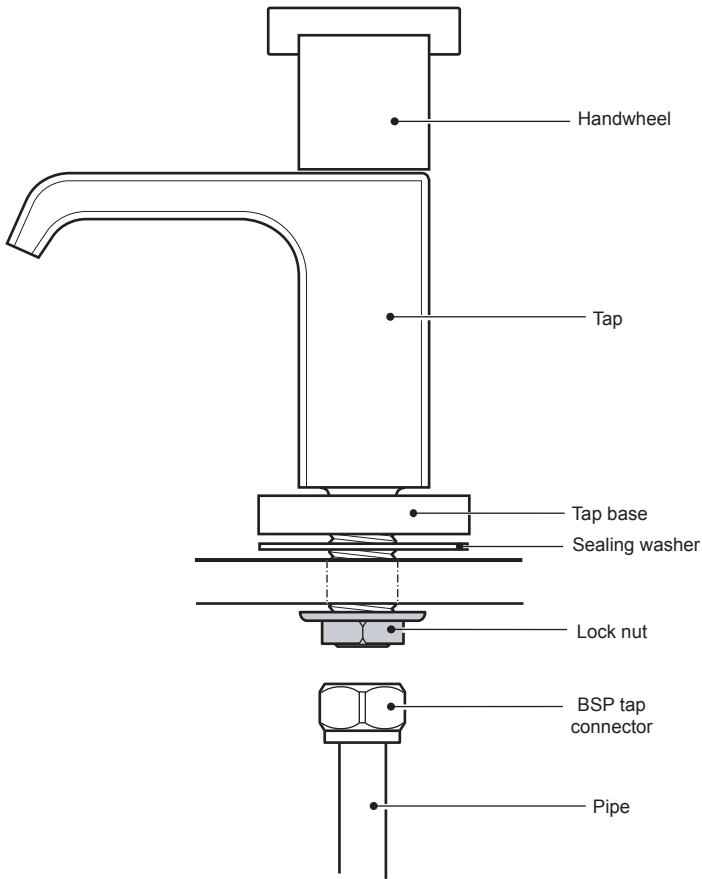

CLEANING

DO NOT use abrasive or solvent cleaning fluids. The taps should be cleaned using a soft cloth and warm water. Any stains should be removed using washing up liquid.

SPARE PARTS

<i>Description</i>	<i>Part No.</i>
½ turn ceramic cartridge (½")	83309260
Complete handwheel (pair)	83309340
Basin tap fixing kit	83309320

Service Policy

In the event of a complaint occurring, the following procedure should be followed:

- 1 Telephone Customer Service on 0870 067 3333 (0845 762 6591 in Scotland and in Northern Ireland), having available the model number and power rating of the product, together with the date of purchase.
- 2 Triton Customer Service will be able to confirm whether the fault can be rectified by either the provision of a replacement part or a site visit from a qualified Triton service engineer.
- 3 If a service call is required the unit must be fully installed for the call to be booked and the date confirmed. In order to speed up your request, please have your postcode available when booking a service call.
- 4 It is essential that you or an appointed representative (who must be a person of 18 years of age or more) is present during the service engineer's visit and receipt of purchase is shown.
- 5 A charge will be made in the event of an aborted service call by you but not by us, or where a call under the terms of guarantee has been booked and the failure is not product related (i.e. scaling and furring, incorrect water pressure).
- 6 If the product is no longer covered by the guarantee, a charge will be made for the site visit and for any parts supplied.
- 7 Service charges are based on the account being settled when work is complete, the engineer will then request payment for the invoice. If this is not made to the service engineer or settled within ten working days, an administration charge will be added.

Replacement Parts Policy

Availability: It is the policy of Triton to maintain availability of parts for the current range of products for supply after the guarantee has expired. Stocks of spare parts will be maintained for the duration of the product's manufacture and for a period of five years thereafter.

In the event of a spare part not being available a substitute part will be supplied.

Payment: The following payment methods can be used to obtain spare parts:

- 1 By post, pre-payment of pro forma invoice by cheque or money order.
- 2 By telephone, quoting credit card (MasterCard or Visa) details.
- 3 By website order, www.tritonshowers.co.uk

TRITON STANDARD GUARANTEE

Triton guarantee this product against all mechanical defects arising from faulty workmanship or materials for a period of five years for domestic use only, from the date of purchase, provided that it has been installed by a competent person in full accordance with the fitting instructions.

Any part found to be defective during this guarantee period we undertake to repair or replace at our option without charge so long as it has been properly maintained and operated in accordance with the operating instructions, and has not been subject to misuse or damage.

This product must not be taken apart, modified or repaired except by a person authorised by Triton. This guarantee applies only to products installed within the United Kingdom and does not apply to products used commercially. This guarantee does not affect your statutory rights.

What is not covered:

- 1 Breakdown due to: *a*) use other than domestic use by you or your resident family; *b*) wilful act or neglect; *c*) any malfunction resulting from the incorrect use or quality of water or incorrect setting of controls; *d*) faulty installation.
- 2 Repair costs for damage caused by foreign objects or substances.
- 3 Total loss of the product due to non-availability of parts.
- 4 Compensation for loss of use of the product or consequential loss of any kind.
- 5 Call out charges where no fault has been found with the appliance.
- 6 The cost of repair or replacement of showerheads, hoses, riser rails and/or wall brackets or any other accessories installed at the same time.
- 7 The cost of routine maintenance, adjustments, overhaul modifications or loss or damage arising therefrom, including the cost of repairing damage, breakdown, malfunction caused by corrosion, furring, pipe scaling, limescale, system debris or frost.

Customer Service: ☎ 0870 067 3333

**Scottish and Northern Ireland
Customer Service:** ☎ 0845 762 6591

Trade Installer Hotline: ☎ 0870 067 3767
Fax: 0870 067 3334

www.tritonshowers.co.uk

E mail: technical@tritonshowers.co.uk

Triton Showers
Triton Road
Nuneaton
Warwickshire CV11 4NR

Triton is a division of Norcross Group (Holdings) Limited