

**TRITON**

# Thermostatic Shower Tower



## Installation and Operating Instructions

INSTALLERS PLEASE NOTE THESE INSTRUCTIONS ARE TO BE LEFT WITH THE USER

<b>CONTENTS</b>	<b>Page</b>
Introduction	1
Safety warnings	1
Main components	2
Site requirements	3
Typical installations	4 - 5
Siting of shower	6
Installation	6 - 9
Operation	9 - 10
Cleaning	10
Spare parts	11
Fault finding	12 - 13
Guarantee, service policy, etc.	rear cover

To check the product suitability for commercial and multiple installations, please contact Triton's specification advisory service before installation.

Telephone: 0870 067 3767

Facsimile: 0870 067 3334

E mail: [technical@tritonshowers.co.uk](mailto:technical@tritonshowers.co.uk)

## INTRODUCTION

This book contains all the necessary fitting and operating instructions for your Triton Thermostatic Shower Tower. Please read them carefully.

Read through the whole of this book before beginning your installation.

*The shower installation must be carried out by a suitably competent person and in sequence of this instruction book.*

Care taken during the installation will ensure a long and trouble free life from your shower.

This shower tower is designed to operate on the higher pressure systems found in the UK up to a maximum of 6 bar running pressure.

The shower MUST NOT be subjected to water temperatures above 80°C.

This mixer shower is suitable for fully modulating type combination boilers and multi-point hot water heaters. It is also suitable for thermal storage, unvented systems and pumped gravity systems.

**IMPORTANT:** Before installing with a gas instantaneous water heater, make sure it is capable of delivering hot water at a minimum switch-on flow rate of 3 litres per minute. At flow rates between 3 and 8 litres per minute, the appliance must be capable of raising the water temperature to a minimum of 52°C. Water temperature at the inlet to the mixer must remain relatively constant when flow rate adjustments are made (*refer to the water heater operating manual to confirm compatibility with this shower tower*).

**Note:** Relative to the BTU's rating of the boiler and changes in the ambient temperature of the mains cold water supply it may not be possible to operate all spray functions on the shower tower simultaneously.

This shower tower is supplied with an integral single check valve and integral large area filter in each inlet elbow. Inlet connections are by steel braided hoses having ½" BSP unions.

## SAFETY WARNINGS

- a Layout and sizing of pipework must be such that when other services are used, pressures at the shower control inlets DO NOT fall below the recommended minimum.
- b **DO NOT choose a position where the shower could become frozen.**
- c **DO NOT connect this shower tower to any form of tap or fitting not recommended by the manufacturer.**
- d The showerheads and body jets must be regularly cleaned to remove scale and debris.
- e Conveniently situated isolating valves in each inlet supply must be fitted as an independent method of isolating the shower should maintenance or servicing be necessary.
- f If it is intended to operate the shower in areas of hard water (above 200 ppm temporary hardness), a scale inhibitor may have to be fitted. For advice on the Triton scale inhibitor, please contact Customer Service.
- g **DO NOT operate the shower outside the guidelines as laid out in 'site requirements'.**
- h **If fitting onto a tiled wall DO NOT tile around the unit.** Always fit the unit on the tiles as this will ease access for servicing.

Replacement parts can be ordered from Triton Customer Service. See 'spare parts' for details and part numbers.

Due to continuous improvement and updating, specification may be altered without prior notice.

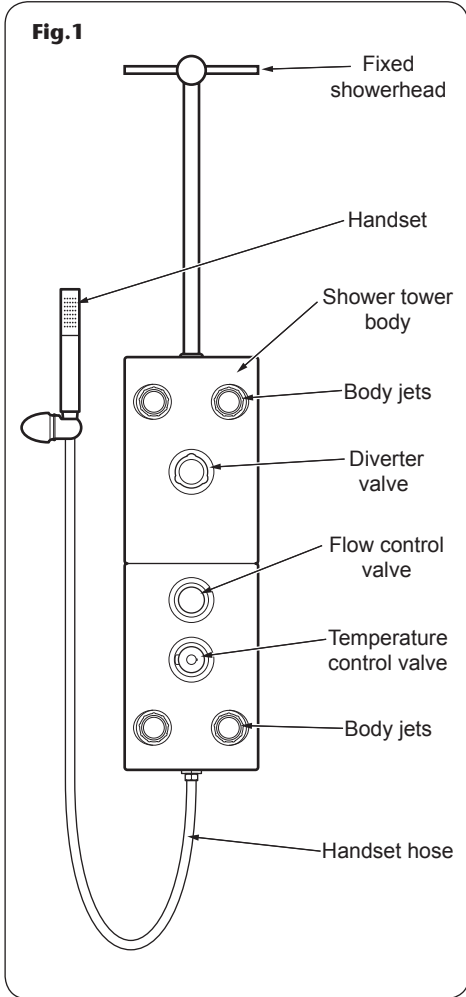

## MAIN COMPONENTS

Thank you for purchasing our high quality product. Check components and quantity before installation. In the unlikely event of anything being amiss, please contact Triton Customer Service.

### Pack contents (fig.1)

Shower tower body  
 Handset and hose - 1 of  
 Elbows with filters and check valves - 2 off  
 Hanging brackets - 2 off  
 Corner hanging brackets - 2 off  
 Screws and wall plugs - 4 off  
 Guarantee

### Important notes before you start

This product has passed a factory control test before reaching you. DO NOT attempt to dismantle or modify it.

- Check there are no hidden service pipes and cables where you intend to drill.
- Check the hot and cold supply pipes are flushed out before final connection to the unit.
- The working pressure of this product is 2 bar to 6 bar (7 bar static).
- Please be aware of your safety while drilling and installing.

### WARNING!

**This product is NOT suitable for low pressure gravity fed supplies unless a suitable pump is also installed.**

### SITE REQUIREMENTS

The installation must be in accordance with Water Regulations and Byelaws.

- Minimum running water pressure: 2 bar
- Maximum running water pressure: 6 bar
- Maximum static water pressure: 7 bar

Both hot and cold supplies should be at nominally equal pressures with a minimum flow rate of 8 litres per minute to both inlets.

While the shower tower is operational (open outlet), inlet pressures must not be capable of exceeding 6 bar. For effective operation of the internal seals, the maximum static pressure must not be exceeded.

**Note:** On sites where the running pressure is above 6 bar, the use of a suitably sized pressure reducing valve fitted in the cold mains supply pipework can provide nominally equal pressures at the shower tower.

For a satisfactory performance from the shower tower both cold and hot inlet supplies must be from a balanced supply.

Additional isolating valves **MUST** be fitted as an independent means of isolating the water supplies should maintenance be necessary.

The pipework should be installed such that the flow is not significantly affected by other taps and appliances being operated elsewhere on the premises.

**Note:** Where thermal store systems and instantaneous gas water heaters are used, if excessive draw offs take place the boiler may not be able to maintain an adequate flow rate and output temperature. This could result in the shower tower temperature becoming noticeably cooler and a reduction in performance.

**DO NOT use jointing compounds on pipework.**

### Water temperature requirements

Recommended maximum 65°C.

BS 6700 recommends the temperature of stored water should never exceed 65°C.

A stored water temperature of 60°C is considered sufficient to meet all normal requirements and will minimise the effects of scale in hard water areas.

### Temperature adjustment range

The mixed water temperature can be adjusted from cold through to the temperature of hot water available from the hot water appliance.

### Flow rate performance

For all systems, the ability to use showerheads and body jets simultaneously is dependent on domestic hot water pressures and flow rates.

**Note:** For the body jets and showerhead to run at the same time there must be a minimum pressure of 2 bar.

**Fig.2** (diagrammatic view – not to scale)

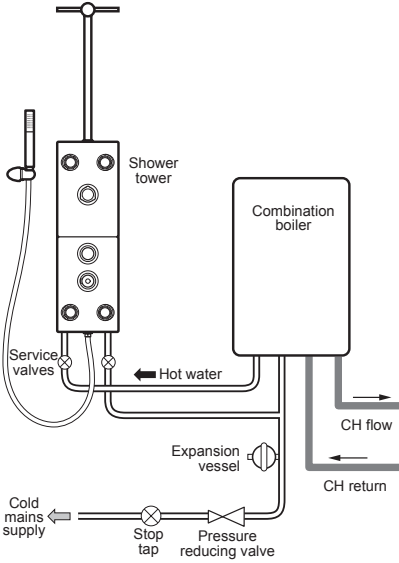

**TYPICAL SUITABLE INSTALLATIONS**

**a) Instantaneous gas-heated systems, e.g. combination boilers (fig.2)**

The shower tower can be installed with a multipoint gas water heater or combination boiler of a fully modulating design (i.e. to maintain relatively stable hot water temperatures).

A drop tight pressure reducing valve **MUST** be fitted if the supply pressures exceed 6 bar running.

An expansion vessel (typically sized at 0.16 litres) as shown in (fig.2), **MUST** be fitted and regularly maintained, to ensure the shower mixer is not damaged by excess pressures. This may already be installed within the boiler (check with manufacturer) and is in addition to the normally larger central heating expansion vessel.

The layout and sizing of pipework **MUST** be such that nominally equal inlet supply pressures are achieved and the effects of other draw-offs are minimised.

**b) Unvented mains pressure systems (fig.3)**

The shower tower can be installed with an unvented, stored hot water cylinder.

For systems with no cold water take off after the appliance reducing valve, it will be necessary to fit an additional drop tight pressure reducing valve when the mains pressure is over 6 bar. The drop tight pressure reducing valve **MUST** be set at the same value as the unvented package pressure reducing valve (fig.3).

**Note:** An additional expansion vessel (0.16 litres) may be required if a second pressure reducing valve is installed. This does not apply to packages with a cold take off after the pressure reducing valve to the cylinder.

The layout and sizing of pipework **MUST** be such that nominally equal inlet supply pressures are achieved and the effects of other draw-offs are minimised.

**Fig.3** (diagrammatic view – not to scale)

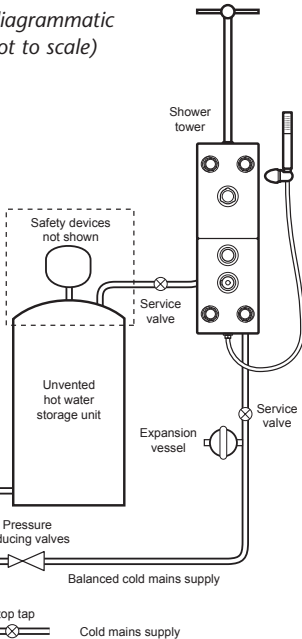

**c) High output thermal store systems (fig.4)**

Packages of this type, fitted with a blender valve can be used. A drop tight pressure reducing valve **MUST** be fitted if the supply pressures exceed 6 bar running.

An expansion vessel (0.16 litres) as shown in **(fig.4)**, **MUST** be fitted and regularly maintained, to ensure the unit is not damaged by excess pressures. This may already be installed externally or internally within the thermal store (check with thermal store manufacturer).

**d) Pump assisted gravity fed systems (fig.5)**

The pump **MUST** be fed from a cold water cistern and hot water cylinder providing nominally equal pressures. To use this shower tower with a gravity fed system will require the use of suitable pump **(fig.5)**.

Refer to the pump installation guide to establish the minimum head requirement for automatic operation of the pump.

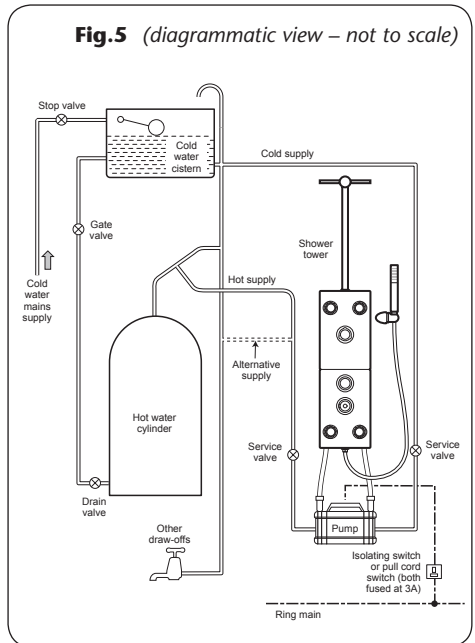
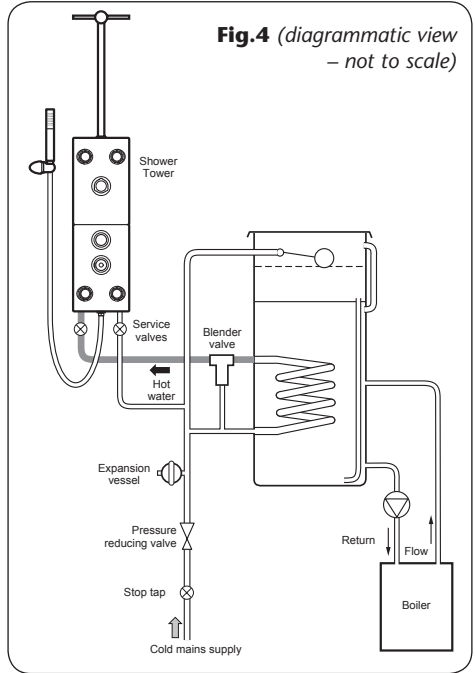

**Fig.6** (diagrammatic view – not to scale)

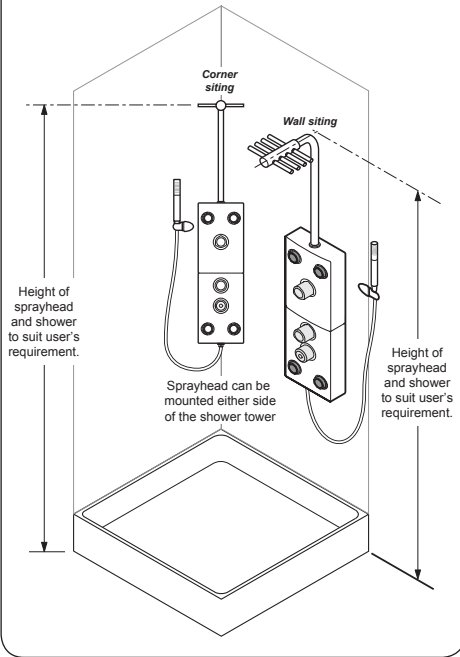

## SITING OF THE SHOWER

### WARNING!

**The shower must not be positioned where it will be subject to freezing conditions.**

Refer to **(fig.6)** for correct siting of the shower.

The shower can be positioned either flush on a wall or in the corner of the cubicle.

Position the shower tower on the wall so that all controls can be comfortably reached while using the shower.

**IMPORTANT:** The hot entry piping is on the left-hand side of the mixer body (as viewed from the front of the unit).

## INSTALLATION

### a) General conditions

**Note:** The outlet of the shower must not be connected to anything other than the hose and showerhead supplied.

DO NOT use jointing compounds on any pipe fittings for the installation.

Use only the fittings supplied.

**DO NOT solder fittings near the unit as heat transfer along the pipework and can damage components.**

**Note:** Suitable isolating valves (complying with Water Regulations and Byelaws) MUST be fitted on the hot and cold water supplies to the shower tower as an independent means of isolating the water supplies should maintenance or servicing be necessary.

When connecting pipework avoid using tight 90° elbows. Swept or formed bends will ensure optimum performance.

**Note:** Water Regulations require that where the showerhead can be lowered into the bath a double check valve or similar device MUST be fitted in the supply pipework to prevent back syphonage.

**IMPORTANT:** The water circuit should be installed such that the flow is not significantly

**Fig.7**

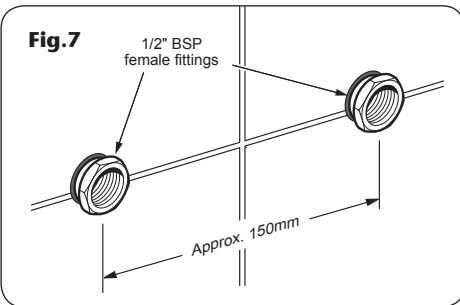

**Fig.8**

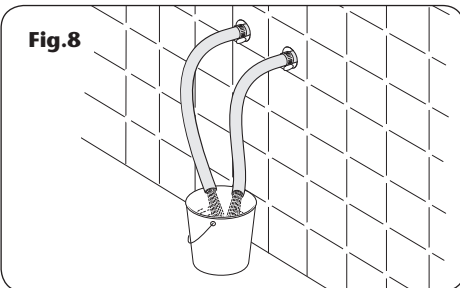

affected by other taps and appliances being operated elsewhere on the premises. Water pressure must not fall below specification of the shower.

**Note:** Hot water pipe entry must be made to the left-hand side inlet.

**b) Instantaneous Gas Water Heaters**

In order to provide the optimum performance from the shower when connected to an instantaneous water heater, the appliance must be capable of raising the temperature of the incoming water to a minimum of 52°C at a flow rate of between three and eight litres per minute.

**c) Fitting the pipework**

Establish the required position of the shower tower and mark two holes for the incoming water supplies.

The suggested final separation between pipe centres is 150mm (fig.7). Note that the pipe centres can be made closer if required.

**Note:** Determining the layout and fitting of pipework for a corner mounted shower tower is beyond the scope of this installation guide.

Remove the plaster and brickwork (or plasterboard) to the depth required and chase out the additional areas to allow for the incoming pipework.

Complete the outlet pipework with a standard 15mm x 1/2" BSP female thread elbow or straight coupler (depending on direction of entry supplies).

**It is preferable to flush the pipework (fig.8) to clear the system of debris and check for leaks before connecting to the elbows.**

Complete any plastering and tiling.

**Note:** Pipes can be surface mounted but cut-outs must be fashioned in the top or bottom of the shower tower.

**d) Fitting the hanging brackets**

**IMPORTANT:** If fitting to a tiled wall, always mount the unit on the surface of the tiles. NEVER tile up to the unit.

Using the centres of the supply holes as the

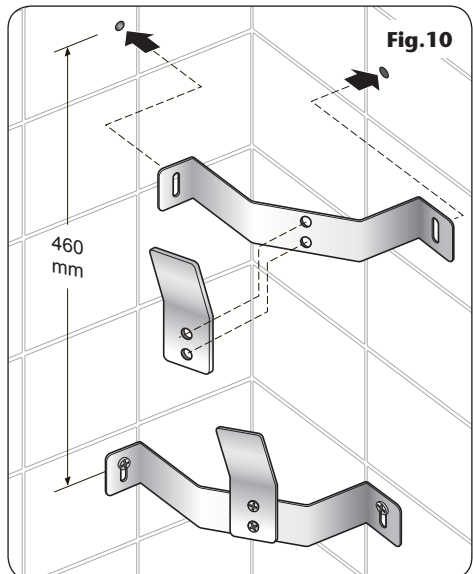
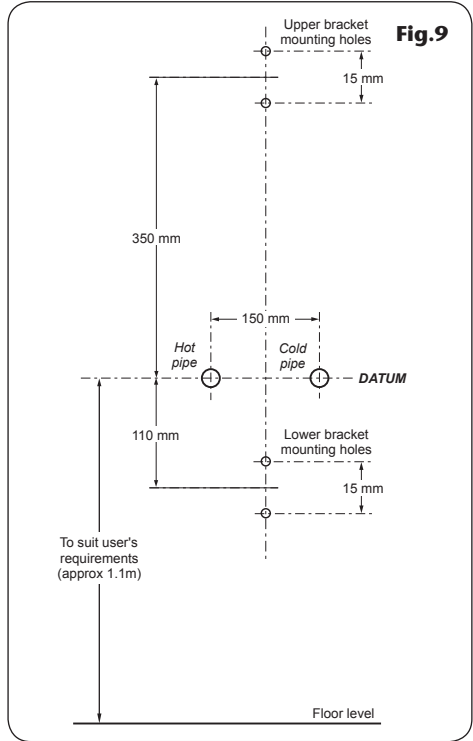

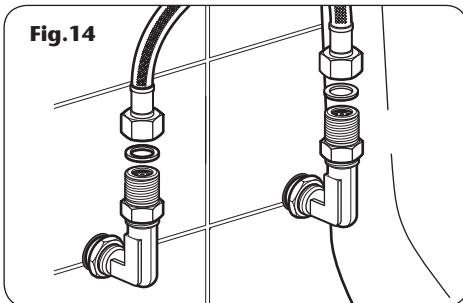
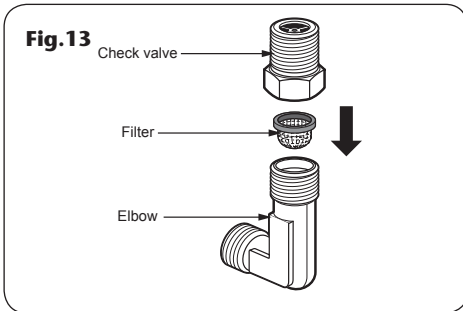
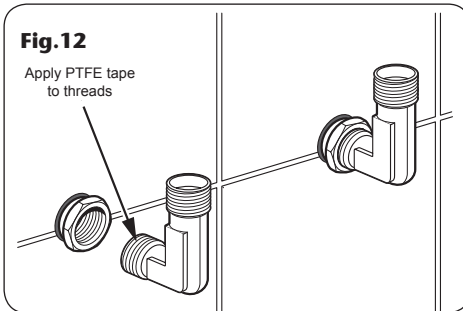
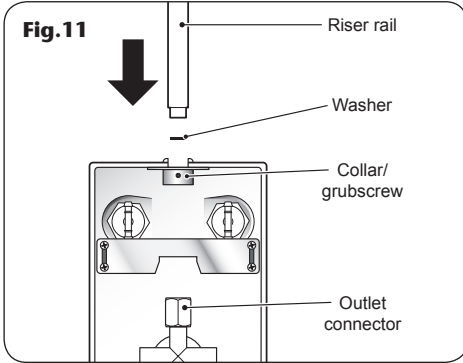

datum line (**fig.9**), mark the position for the four locating screws for the hanging brackets. Check they are vertically and horizontally aligned.

When fitting the corner mounting brackets first fix the flat mounting bracket onto the corner bracket (**fig.10**).

Drill and plug the wall using the wall plugs provided (*the wall plugs are suitable for most brick walls - use an appropriate masonry drill, but if the wall is plasterboard or a soft building block, use special wall plugs and a suitable drill bit*).

Secure the hanging brackets to the wall using the screws supplied.

### e) Fitting the fixed showerhead

Screw the fixed showerhead onto the riser pipe, making sure the sealing washer is in place.

Slide the showerhead/riser pipe assembly through the top of the of the shower tower body (**fig.11**). Wrap the riser pipe thread with PTFE tape and ensuring a sealing washer is in place, screw the riser pipe into the top outlet connector.

Adjust the showerhead so that it faces forwards. Secure in position by tightening the grub screw in the shower tower body collar.

### f) Fitting the shower tower body

Wrap the supplied elbow threads with PTFE tape and connect them to the hot and the cold water pipes. Tighten to prevent leaking and make sure the elbows face up (**fig.12**).

Fit the filter and check valve onto the elbow to prevent debris entering the the mixer valve (**fig.13**).

Facing the front of the shower tower body, connect the left-hand flexible hose inside the unit to the hot water elbow, and then connect the right-hand flexible hose to the cold water elbow (**fig.14**). Make sure there is a gasket in place on each of the hoses.

Screw tightly to avoid leaking.

Hitch the two support bars inside the shower body onto the hanging brackets on the wall. Make sure the installation is stable.

### g) Fitting the hose and showerhead

Select a suitable position for the showerhead bracket. Mark the position of the two holes required and drill and plug the wall. Secure the bracket to the wall using the screws supplied.

Fit the cover trim in place.

Connect the swivel nut of the shower hose to the bottom outlet connector (**fig.15**) on the shower tower body. Screw the other end of the hose to the handset then locate the handset into the handset bracket.

**Check the pipework is stable and watertight to avoid leaks before using the shower tower.**

**Note:** DO NOT use silicon sealant around the shower tower since it may be necessary to access and clean the inlet filters periodically.

## OPERATION

### Using the flow control

Rotate the flow control anti-clockwise and water will flow from the outlets, depending on which has been selected via the diverter valve. Rotate the control clockwise and the water flow will stop (**fig.16**).

### Using the temperature control

To obtain hot water turn the temperature control anti-clockwise. To obtain cooler water turn the temperature control clockwise.

The shower tower is fitted with a maximum temperature override button factory set at 38°C. To override the maximum temperature press the red button on the control as you turn it anti-clockwise. To return to a cooler temperature simply rotate the control clockwise.

This should be checked to make sure the setting has not been altered and to ensure user safety.

### Using the diverter valve

The diverter valve controls which of the water outlets operate.

**Note:** The diverter valve (**fig.16**) will only operate if the flow control is on. The temperature adjustment is controlled only from the temperature control.

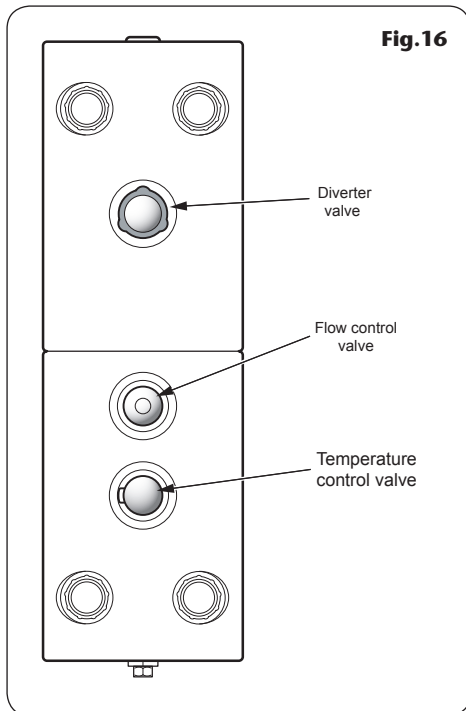
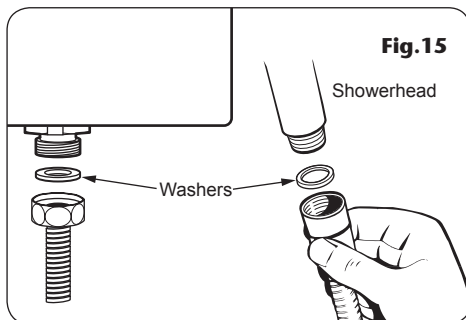

Turn the diverter to the indicated position.



Turning the control to this position will allow water to flow from the fixed head.



Turning the control to this position will allow water to flow from the body jets.



Turning the control to this position will allow water to flow from the handset.



Rotating the control to this position will turn the handset and body jets on.



Turning the control to this position will turn the fixed head and jets on.

**CAUTION:** It is recommended that persons who may have difficulty understanding or operating the controls should not be left unattended while using the shower tower. Special consideration should be given to young children and the less able bodied.

### **WARNING!**

**DO NOT use 'powerful' abrasive or solvent cleaning fluids when cleaning the shower as they may damage the plastic fittings.**

### **CLEANING**

**DO NOT use abrasive or solvent cleaning fluids.** Clean the unit frequently using a soft cloth and warm water.

#### **Cleaning the showerhead and diverters**

To clean the showerhead and diverters simply rub your thumb over the nozzles.

**SPARE PARTS**

<b>Ref.</b>	<b>Description</b>	<b>Part No.</b>
1	Fixed showerhead	7993118
2	Diverter control knob	7993124
3	Diverter control valve assembly	7993120
4	Flow control knob	7993125
5	Flow control trim	7993126
6	Flow control valve assembly	7993122
7	Temperature control valve assembly (including control knob)	7993127
8	Body jet (4 off)	7993123
9	PVC hose	7993119
10	Braided hose - 160mm	7993121
11	Braided hose - 300mm	7993117
12	One-way valve	7993109
13	Filter	7993101
14	Elbow	7993110
15	Hanging bracket	7993112
16	Handset	7993128
17	Handset hose	7993094
-	Fixed wall bracket	7993129

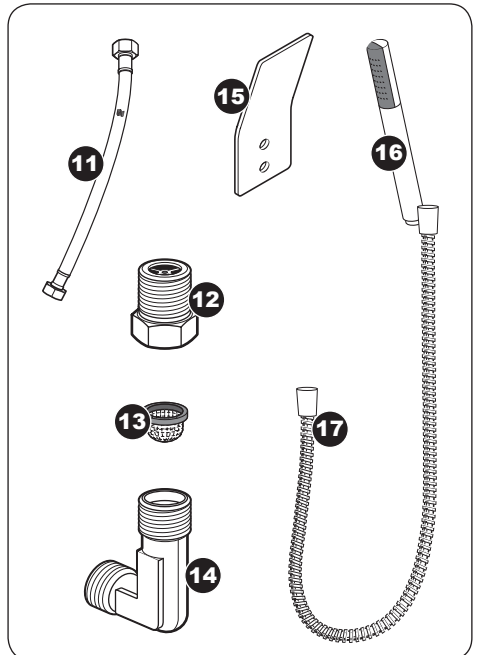
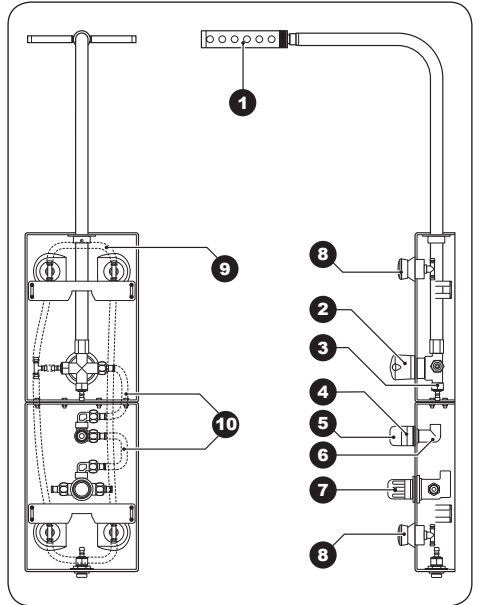

## FAULT FINDING

The following can be carried out by a competent person

<i>Problem/Symptom</i>	<i>Cause</i>	<i>Action/Cure</i>
<b>1</b> Water too hot.	<b>1.1</b> Not enough cold water flowing through shower.	<b>1.1.1</b> Turn temperature control anti-clockwise.
	<b>1.2</b> Increase in the ambient cold water temperature.	<b>1.2.1</b> Turn temperature control anti-clockwise.
	<b>1.3</b> Cold water supply blocked.	<b>1.3.1</b> Check filters are clean. <b>1.3.2</b> Turn shower off and consult a competent plumber or contact Triton Customer Service.
	<b>1.4</b> High volume of cold water drawn off elsewhere.	<b>1.4.1</b> Reduce the simultaneous demand from the supply.
<b>2</b> Water too cold.	<b>2.1</b> Not enough hot water flowing through shower.	<b>2.1.1</b> Turn the temperature control clockwise.
	<b>2.2</b> Decrease in the ambient cold water temperature.	<b>2.2.1</b> Turn the temperature control clockwise.
	<b>2.3</b> Insufficient hot water supplies from the heating system.	<b>2.3.1</b> Make sure heating appliance is set to maximum or has sufficient stored hot water. <b>2.3.2</b> Ensure heating appliance is igniting by trying a hot water tap elsewhere.
	<b>2.4</b> Hot water supply blocked or restricted.	<b>2.4.1</b> Check the filters are clean. <b>2.4.2</b> Turn shower off and consult a competent plumber or contact Triton Customer Service.
<b>3</b> Water does not flow or shower pattern collapses when another outlet is turned on.	<b>3.1</b> Water supplies cut off.	<b>3.1.1</b> Check water elsewhere in house and if necessary contact local water company.
	<b>3.2</b> Shower unit blocked.	<b>3.2.1</b> Inspect the inlet filters. Clean if necessary.
	<b>3.3</b> Blockage in pipework.	<b>3.3.1</b> Turn the shower off and consult a suitably competent plumber.
	<b>3.4</b> Showerhead blocked.	<b>3.4.1</b> Clean showerhead.
	<b>3.5</b> System not capable of supplying multiple outlets at the same time.	<b>3.5.1</b> Reduce the simultaneous demand. <b>3.5.2</b> Ensure stop/service valves are fully open. <b>3.5.3</b> Check if sufficient water pressure.
	<b>3.6</b> Check valve sticking.	<b>3.6.1</b> Inspect check valves in H/C supply elbows.

## FAULT FINDING

**The following is recommended for a professional qualified installer only**

<i><b>Problem/Symptom</b></i>	<i><b>Cause</b></i>	<i><b>Action/Cure</b></i>
<b>4</b> Water too cold.	<b>4.1</b> Running pressure in excess of maximum recommended.	<b>4.1.1</b> Fit a pressure reducing valve.
<b>5</b> Shower controls noisy while in use.	<b>5.1</b> Running pressure in excess of maximum recommended.	<b>5.1.1</b> Fit a pressure reducing valve.
<b>6</b> Shower will not shut off.	<b>6.1</b> Pipework not flushed before connecting the unit (flow control valve damaged).	<b>6.1.1</b> Renew flow control valve.



## Service Policy

In the event of a complaint occurring, the following procedure should be followed:

- 1 Telephone Customer Service on 0870 067 3333 (0845 762 6591 in Scotland and in Northern Ireland), having available the model number and power rating of the product, together with the date of purchase.
- 2 Triton Customer Service will be able to confirm whether the fault can be rectified by either the provision of a replacement part or a site visit from a qualified Triton service engineer.
- 3 If a service call is required the unit must be fully installed for the call to be booked and the date confirmed. In order to speed up your request, please have your postcode available when booking a service call.
- 4 It is essential that you or an appointed representative (who must be a person of 18 years of age or more) is present during the service engineer's visit and receipt of purchase is shown.
- 5 A charge will be made in the event of an aborted service call by you but not by us, or where a call under the terms of guarantee has been booked and the failure is not product related (i.e. scaling and furring, incorrect water pressure).
- 6 If the product is no longer covered by the guarantee, a charge will be made for the site visit and for any parts supplied.
- 7 Service charges are based on the account being settled when work is complete, the engineer will then request payment for the invoice. If this is not made to the service engineer or settled within ten working days, an administration charge will be added.

## Replacement Parts Policy

**Availability:** It is the policy of Triton to maintain availability of parts for the current range of products for supply after the guarantee has expired. Stocks of spare parts will be maintained for the duration of the product's manufacture and for a period of five years thereafter.

In the event of a spare part not being available a substitute part will be supplied.

**Payment:** The following payment methods can be used to obtain spare parts:

- 1 By post, pre-payment of pro forma invoice by cheque or money order.
- 2 By telephone, quoting credit card (MasterCard or Visa) details.
- 3 By website order, [www.tritonshowers.co.uk](http://www.tritonshowers.co.uk)

Triton Showers  
Triton Road  
Nuneaton  
Warwickshire CV11 4NR

*Triton is a division of Norcross Group (Holdings) Limited*

## TRITON STANDARD GUARANTEE

Triton guarantee this product against all mechanical defects arising from faulty workmanship or materials for a period of one year for domestic use only, from the date of purchase, provided that it has been installed by a competent person in full accordance with the fitting instructions.

Any part found to be defective during this guarantee period we undertake to repair or replace at our option without charge so long as it has been properly maintained and operated in accordance with the operating instructions, and has not been subject to misuse or damage.

This product must not be taken apart, modified or repaired except by a person authorised by Triton. This guarantee applies only to products installed within the United Kingdom and does not apply to products used commercially. This guarantee does not affect your statutory rights.

### What is not covered:

- 1 Breakdown due to: *a)* use other than domestic use by you or your resident family; *b)* wilful act or neglect; *c)* any malfunction resulting from the incorrect use or quality of water or incorrect setting of controls; *d)* faulty installation.
- 2 Repair costs for damage caused by foreign objects or substances.
- 3 Total loss of the product due to non-availability of parts.
- 4 Compensation for loss of use of the product or consequential loss of any kind.
- 5 Call out charges where no fault has been found with the appliance.
- 6 The cost of repair or replacement of showerheads, hoses, riser rails and/or wall brackets or any other accessories installed at the same time.
- 7 The cost of routine maintenance, adjustments, overhaul modifications or loss or damage arising therefrom, including the cost of repairing damage, breakdown, malfunction caused by corrosion, furring, pipe scaling, limescale, system debris or frost.

**Customer Service:** ☎ 0870 067 3333

**Scottish and Northern Ireland**

**Customer Service:** ☎ 0845 762 6591

**Trade Installer Hotline:** ☎ 0870 067 3767

**Fax:** 0870 067 3334

**[www.tritonshowers.co.uk](http://www.tritonshowers.co.uk)**

**E mail:** [technical@tritonshowers.co.uk](mailto:technical@tritonshowers.co.uk)