



For a cleaner conscience

ENlight®

Electric Shower



Installation Instructions

Please read this book thoroughly and familiarise yourself with all instructions before commencing installation and keep it for future reference.

The installation **MUST** be carried out by a suitably qualified person, **in the sequence of this instruction book.**

IMPORTANT SAFETY ADVICE

The ENLIGHT® Shower **MUST BE** switched off at the isolating switch when not in use. This is a safety procedure recommended for all electrical appliances.

The shower head and hose supplied with this product are safety critical parts of your shower. Failure to use genuine Triton parts may cause injury and invalidate your guarantee.

IMPORTANT SAFETY INFORMATION

Products manufactured by Triton are safe and without risk, provided they are installed, used and maintained in good working order in accordance with our instructions and recommendations.

- ⚠ **WARNING: DO NOT** operate the shower if there is a possibility of frozen water within the heater or pipes feeding the shower.
- ⚠ **DO NOT** operate the shower if the shower head or spray hose becomes damaged.
- ⚠ **DO NOT** restrict flow out of shower by placing shower head in direct contact with your body or any other surface.
- ⚠ **DO NOT** operate the shower if water ceases to flow during use.
- ⚠ **WARNING:** If restarting the shower immediately after stopping, be aware that a slug of hot water could be expelled for the first few seconds.
- ⚠ Any spray head must be descaled regularly.
- ⚠ Fit only shower heads and hoses recommended by the manufacturer and never fit any additional device to restrict the water outlet flow.
- ⚠ The outlet must not be connected to any tap or fitting other than those specified by the manufacturer.
- ⚠ This appliance is intended to be permanently connected to the water mains and not connected by a hose set.
- ⚠ The water inlet of this appliance must only be connected to mains cold water supply. The water inlet must never be connected through any other water heating system.
- ⚠ **WARNING:** This appliance is not to be used to provide a potable water supply.
- ⚠ A suitable double pole isolation switch for supply disconnections must be incorporated in the fixed wiring circuit in accordance with current wiring regulations. See Electrical Installation section for further details.
- ⚠ Always disconnect the appliance from the supply before assembling, disassembling or cleaning.
- ⚠ Mains water pressure only.
- ⚠ Minimum Dynamic inlet pressure 100kPa (1 bar)
Maximum Static inlet pressure 1000kPa (10 bar)

This book contains all the necessary fitting and operating instructions for your electric shower. Care taken during the installation will provide a long, trouble-free life from your shower.

⚠ WARNING ⚠

This appliance can be used by children aged from 3 years and above and persons with reduced physical, sensory or mental capabilities or lack of experience and knowledge if they have been given supervision or instruction concerning use of the appliance in a safe way and understand the hazards involved. Children may not play with the appliance. Cleaning and user maintenance shall not be made by children.

IMPORTANT SAFETY INFORMATION

GENERAL

- Isolate the electrical and water supplies before removing the cover.
- Read all of these instructions and retain them for later use.
- **DO NOT** take risks with plumbing or electrical equipment.
- Isolate electrical and water supplies before proceeding with the installation.
- The shower unit must be mounted onto the finished wall surface (on top of the tiles). **DO NOT** tile up to or seal around **ANY PART** of the unit using silicone sealer after fixing to the wall. Special care must be taken **NOT TO BLOCK OR SEAL ANY PRD VENTS ON THE UNIT.**
- Contact Customer Experience (see back page), if any of the following occur:
 - If it is intended to operate the shower at pressures above the maximum or below the minimum stated.
 - If the unit shows a distinct change in performance.
- If it is intended to operate the shower in areas of hard water (above 200 ppm temporary hardness), a scale inhibitor may have to be fitted. For advice on the scale inhibitor, contact Customer Experience.
- The shower head must be cleaned regularly with descalent to remove scale and debris, otherwise restrictions to the flow on the outlet of the unit will result in reduced thermostatic performance.
- This product is not suitable for mounting into steam rooms, steam cubicles or exposed to outdoor elements.

PLUMBING

- The plumbing installation must comply with Water Regulations, Building Regulations or any particular regulations as specified by Local Water Company or Water Undertakers and should be in accordance with BS EN 806.
- The supply pipe must be flushed to clear debris before connecting to the shower unit.
- **DO NOT** solder fittings near the shower unit as heat can travel along pipework and damage components.
- **DO NOT** fit any form of outlet flow control as the outlet acts as a vent for the heater can.
- **DO NOT** use excessive force when making connections to the flexible hose or shower head, finger tight is sufficient.
- All plumbing connections must be completed before making the electrical connections.

ELECTRICAL

- The installation must comply with BS 7671 'Requirements for electrical installations' (IEE wiring regulations), building regulations or any particular regulations as specified by the local Electrical Supply Company.
- This appliance **MUST** be earthed.
- In accordance with 'The Plugs and Sockets etc. (Safety) Regulations 1994', this appliance is intended to be permanently connected to the fixed wiring of the electrical mains system.
- Make sure all electrical connections are tight to prevent overheating.
- A 30mA residual current device (RCD) **MUST** be installed in all UK electric and pumped shower circuits. This may be part of the consumer unit or a separate unit.
- Switch off immediately at isolating switch if water ceases to flow during use.
- Other electrical equipment i.e. extractor fans, pumps, must not be connected to the circuits within the unit.
- Switch off at the isolating switch when not in use. This is a safety procedure recommended with all electrical appliances.
- As with all electrical appliances it is recommended to have the shower and installation checked at least every two years by a competent electrician to ensure there is no deterioration due to age and usage.

CONTENTS

	Page
Important Safety Information	2
Introduction	
Advice to Users	5
Product Fiche	5
Specification	6
WEEE Policy Statement	6
Dimensions and Connections	7
Main Components	8
Installation Requirements	
Plumbing	9
Diagrammatic View	10
Electrical	11
Installation	
Positioning	13
Step by Step Instruction	13
Shower Settings	17
Commissioning	18
Maintenance	
Inlet Filter	21
Fault Diagnostics	22
UK Service policy / Guarantee, etc.	Rear

INTRODUCTION

Please read this book thoroughly and familiarise yourself with all instructions before commencing installation.

Please keep it for future reference.

The shower installation **MUST** be carried out by a suitably qualified person, in the sequence of these instructions.

ADVICE TO USERS

IMPORTANT: When first installed, the shower unit will be empty of water. It is essential that the heater assembly should contain water before the heating elements are switched on. It is vital that the commissioning procedure is followed. Failure to carry out this operation will result in damage to the unit and will invalidate the guarantee.

The following points will help you understand how the shower operates:

- a) The temperature controls can be adjusted to provide shower temperatures between 35°C and 45°C (or ambient if cold mode is activated).
- b) During winter, the mains water supply will be cooler than in the summer. The water flow rate will therefore vary between seasons, the thermostatic control of the shower unit will automatically maintain the desired temperature.
- c) At any selected showering temperature the unit will automatically provide the optimum flow rate possible.

IT IS ADVISED THAT WHERE THE PROPERTY IS LEFT UNATTENDED FOR AN EXTENDED PERIOD OF TIME, THAT THE WATER AND ELECTRICITY SUPPLIES TO THE SHOWER UNIT ARE ISOLATED.

PRODUCT FICHE	
Model	9.5kW
Load Profile	XS
Energy Efficiency Class	A
Energy Efficiency (%)	39
Annual Electricity Consumption (kWh)	477
Sound Power Level (db)	15

SPECIFICATION

Electrical	
Nominal Power Rating at 240V	9.5kW
Nominal Power Rating at 230V	8.7kW
Supply Fuse/Miniature Circuit Breaker (MCB)	45Amps
Residual Current Device (RCD)	30mA
Isolation Switch	45Amp Double Pole isolating switch (with 3mm minimum contact gap)
Supply Cable	16mm ² Maximum (refer to Electrical Requirements)
Water Supply	
Supply Type	Mains pressure cold water only
Minimum Pressure (Dynamic)	100kPa (1 bar) @ 8 litres per minute
Maximum Pressure (Static)	1000kPa (10 bar)
Inlet Water Temperature	2°C - 28°C
Inlet Water Connection	15mm Stem (suitable for de-mountable push-fit and compression fittings)
Outlet Water Connection	1/2" BSP male thread

Accreditations



IP24

WEEE Directive – Policy Statement

As a producer and a supplier of water heaters, Triton Showers is committed to the protection of the environment via our own environmental policy and the compliance with the **WEEE directive**.

Triton Showers is fully registered with the Environment Agency under the following schemes:

Repic: Producers take-back scheme (PTS), registration number WEE/EJ3466QV

Valpak: Distributor take-back scheme (DTS), registration number DTS-700160



All our electric products are labelled accordingly with the crossed out wheeled bin symbol. This indicates, for disposal purposes at end of life, that these products must be taken to a recognised collection points, such as local authority sites/local recycling centres; this will be free of any charges. **Do not return to Triton Showers.**

DIMENSIONS & CONNECTIONS



Mains Electricity Cable Entry Points 

Water Supply Pipe Entry Points 

MAIN COMPONENTS

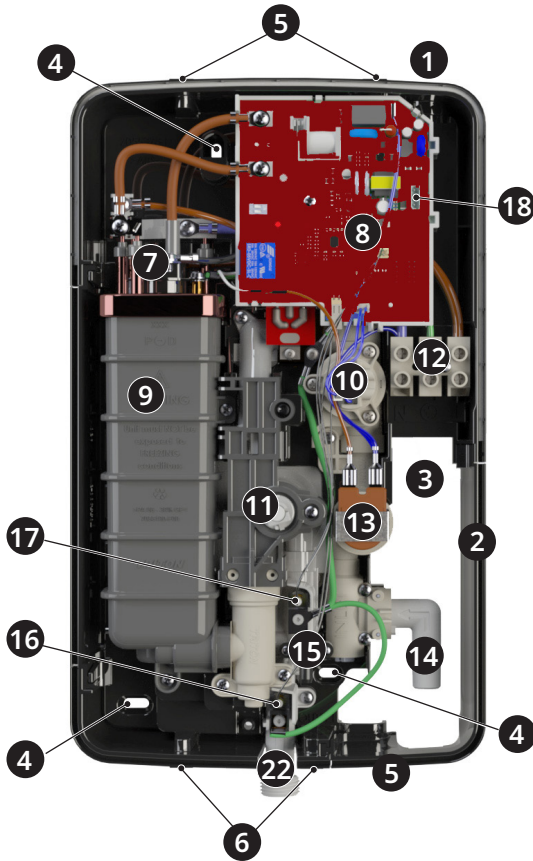

1. Top Cable and Pipe Entry
2. Bottom Corner Trim
3. Rear Cable and Pipe Entry
4. Wall Fixing Positions
5. Bottom Cable and Pipe Entry
6. Cover Fixing Screw Positions
7. Thermal Safety Cut-Out
8. Control P.C.B.
9. Heater Can Assembly
10. Pressure Switch Assembly
11. Thermostatic Valve Assembly

12. Electrical Connection Block
13. Solenoid Valve
14. Water Inlet Connection
15. Pressure Relief Device (PRD)
16. Outlet Thermistor
17. Heater Can Thermistor
18. Cover Connector Socket
19. Cover Connector
20. Button P.C.B.
21. Display P.C.B.
22. Shower Outlet
23. Front Cover Assembly

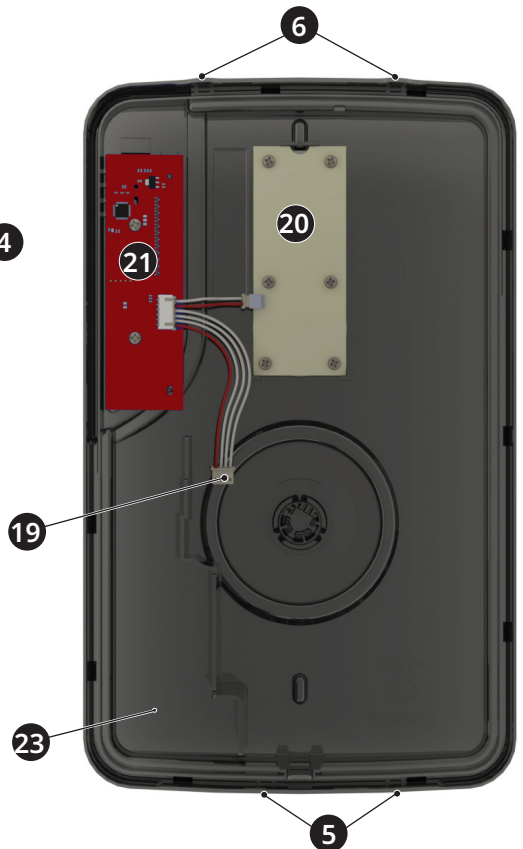

INSTALLATION REQUIREMENTS

PLUMBING REQUIREMENTS

Please read **IMPORTANT SAFETY INFORMATION** and **SPECIFICATION** sections before undertaking the plumbing installation.

NOTE: If the recommended dynamic pressure and flow is not available, there could be a noticeable reduction in performance from the shower head.

If it is intended to operate the shower at pressures above the maximum or below the minimum stated, contact Customer Experience for advice.

1. The installation must be in accordance with Water Regulations/Bylaws.
3. **DO NOT** use jointing compounds on any pipe fittings for the installation.
4. **DO NOT** solder fittings near the shower unit as heat can travel along pipe work and damage components.
5. Compression or demountable push-fit fittings can be used to connect to the Water Inlet connector.
6. **NOTE:** DO NOT use non-demountable push-fit fittings as this will prevent servicing and may invalidate the warranty of the product.
7. **Important:** An additional full bore stop valve (complying with Water Regulations) must be fitted in the mains water supply to the shower as an independent means of isolating the water to carry out maintenance or servicing. If this isolator is fitted in a loft space, the loft must have a fixed access ladder and be boarded, with appropriate lighting from the access point to the isolator.
8. **Important:** Before completing the connection of the water supply to the inlet of the shower, flush out the pipe work to remove all swarf and system debris.
9. **Important:** The unit must be mounted on a flat surface which covers the full width and length of the backplate. It is important that the wall surface is flat otherwise difficulty may be encountered when fitting the cover and subsequent operation of the unit may be impaired.
10. **Position of the shower:** Refer to **Fig.1** for correct positioning of shower. Position the unit where it will not be in direct contact with water from the shower head. Always mount the shower unit vertically and allow enough room between the ceiling and the shower to access the cover top screws.

IMPORTANT Water Regulations: It is a legal obligation for the premises owner or occupier to ensure the plumbing work is fully compliant with the water fittings regulations. This means that the shower fittings must provide a 25mm minimum air gap between the shower head and spill over level of a Fluid Category 3 backflow risk (bath, shower tray or basin) and a 30mm minimum air gap for a Fluid Category 5 backflow risk (toilet or bidet) see **Fig.1**. If these minimum distances cannot be achieved then a double check valve, or similar device, **MUST be fitted in to prevent back siphonage of water.**

INSTALLATION REQUIREMENTS

WARNING
 The Shower unit **MUST NOT** be positioned where it will be subjected to freezing conditions.

Fig.1 Diagrammatic view (not to scale)

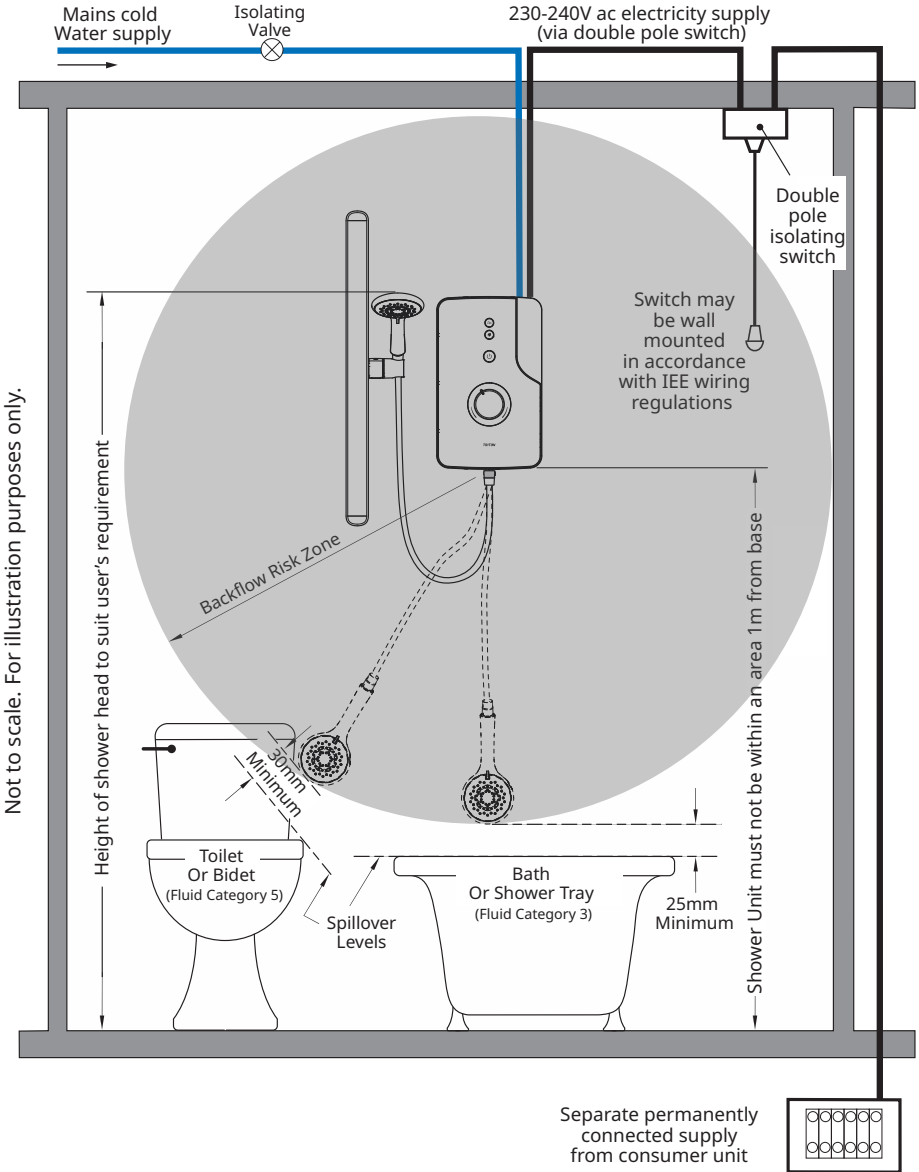

INSTALLATION REQUIREMENTS

ELECTRICAL REQUIREMENTS

Please read **IMPORTANT SAFETY INFORMATION** and **SPECIFICATION** sections before undertaking the electrical installation.

The installation, supply cable and circuit protection must conform with BS 7671 (IEE wiring regulations) and be sufficient for the amperage required.

 **WARNING:** This appliance must be earthed by connecting the supply cable earth conductor to the terminal block within the appliance. It is strongly recommended to use a minimum of 10mm cabling throughout the shower installation.

The following notes are for guidance only:

1. The shower unit must only be connected to a 230-240V AC supply. Any drops in voltage due to localised heavy demand may reduce the shower's performance.
2. The electrical rating of the shower is shown on the rating label (**Fig.3**) which is positioned within the unit.
3. Before making any sort of electrical connection within the installation, make sure that no terminal is live. If in any doubt, isolate the whole installation at the mains supply and remove the correct fuse.
4. The shower unit must be connected to its own independent electrical circuit. **IT MUST NOT** be connected to a ring main, spur socket outlet, lighting circuit or cooker circuit.
5. The electrical supply must be adequate for the loading of the unit and existing circuits.
6. Check your consumer unit (main fuse box) has a main switch rating of 80Amps or above and that it has a spare fuse way which will take the fuse or Miniature Circuit Breaker (MCB) necessary for the shower rating.
7. If your consumer unit has a rating below 80A or if there is no spare fuse way, then the installation will not be straightforward and may require a new consumer unit serving the house or just the shower. Contact a professional electrician/local electricity company for advisement.
8. For close circuit protection **DO NOT** use a rewirable fuse. Instead use a suitably rated Miniature Circuit Breaker (MCB) or cartridge fuse. Triton recommend the following circuit protection: **8.5KW variant - 40Amp 9.5kW variant - 40/45Amp**
9. A 30mA residual current device (RCD) **MUST** be installed in all UK electric shower circuits. This may be part of the consumer unit or a separate unit. A suitably rated RCBO could be used if the RCD is not present and the consumer is compatible with the RCBO.

Fig.2

Twin and earth PVC insulated cable Current carrying capacity		
Installed in an insulated wall	In conduit trunking	Clipped direct or buried in a non-insulated wall
6mm ² 32A	6mm ² 38A	6mm ² 46A
10mm ² 43A	10mm ² 52A	10mm ² 63A
16mm ² 57A	16mm ² 69A	16mm ² 85A

Note: Cable Selection is dependent on derating factors

Fig.3



Triton Showers
Triton Road, Nuneaton
Warwickshire, CV11 4NR.

MODEL ENlight
230 - 240V 
8.7 - 9.5kW

MAX PRESSURE
1000kPa (10bar)

MIN PRESSURE
70kPa (0.7bar)

RATED PRESSURE 0kPa (0bar)

MODEL No. XXXXXXXX
SERIAL No. XXXXXXXX

IP24





Intertek



bsi
BSI
REGISTERED
FOR THE
UK

XX/XX

INSTALLATION REQUIREMENTS

10. A 45 amp double pole isolating switch with a minimum contact gap of 3mm in both poles must be incorporated in the circuit. It must have a mechanical indicator showing when the switch is in the OFF position, and the wiring must be connected to the switch without the use of a plug or socket outlet.
11. The switch must be accessible and clearly identifiable, but out of reach of a person using a fixed bath or shower tray/cubicle, except for the cord of a cord operated switch, and should be placed so that it is not possible to touch the switch body while standing in a bath or shower tray/cubicle. It should be readily accessible to switch off after use.
12. Where shower cubicles are located in any rooms other than bathrooms, all socket outlets in those rooms must be protected by a 30mA RCD.
13. The current carrying capacity of the cable must be at least that of the shower circuit protection (**Fig.2**). To obtain full advantage of the power provided by the shower, use the shortest cable route possible from the consumer unit to the shower.
14. The electrical circuit to the shower should be separated from other circuits by at least twice the diameter of the cable or conduit. The current rating will be reduced if the cabling is bunched with others, surrounded by thermal loft or wall insulation or placed in areas where the ambient temperature is above 30°C. Under these conditions, derating factors apply and it will be necessary to select a larger cable size (**Fig.2**). In the majority of installations, the cable will unavoidably be placed in one or more of the above conditions. This being so, **it is strongly recommended to use a minimum of 10mm² cabling throughout the shower installation.** In any event, it is essential that individual site conditions are assessed by a competent electrician in order to determine the correct cable size and permissible circuit length.

Fig.4 Wiring Diagram

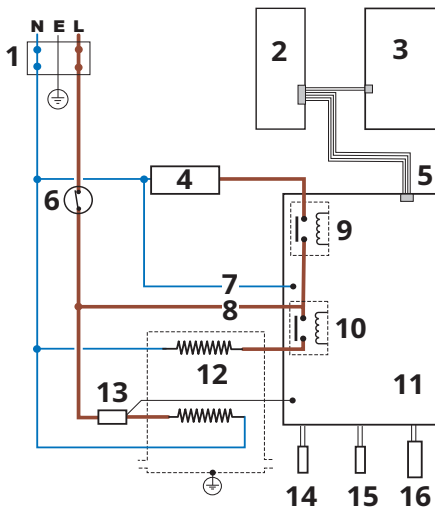

1. Terminal Block
2. Display P.C.B.
3. Button P.C.B.
4. Solenoid
5. Connecting Cable
6. Thermal Safety Cut-Out
7. P.C.B. Neutral Supply
8. P.C.B. Live Supply
9. Relay
10. Relay
11. Control P.C.B.
12. Heater Can
13. Triac
14. Heater Can Thermistor
15. Outlet Thermistor
16. Pressure Switch

INSTALLATION

POSITIONING THE SHOWER

For ease of servicing, the unit must always be mounted on the surface of tiled walls. Never tile up to the unit.

Position the unit where it will not be in direct contact with water from the shower head. Mount the shower unit vertically.

Allow enough room between the ceiling and the shower to access the top cover screws.

Using the supplied template in the centre of this booklet, mark out the entry points and routing of the water and electric supplies into the shower.



Find our step-by-step installation video for this product on our YouTube channel. Go to [youtube.com/TritonShowers](https://www.youtube.com/TritonShowers) and search for 'how to guides'.

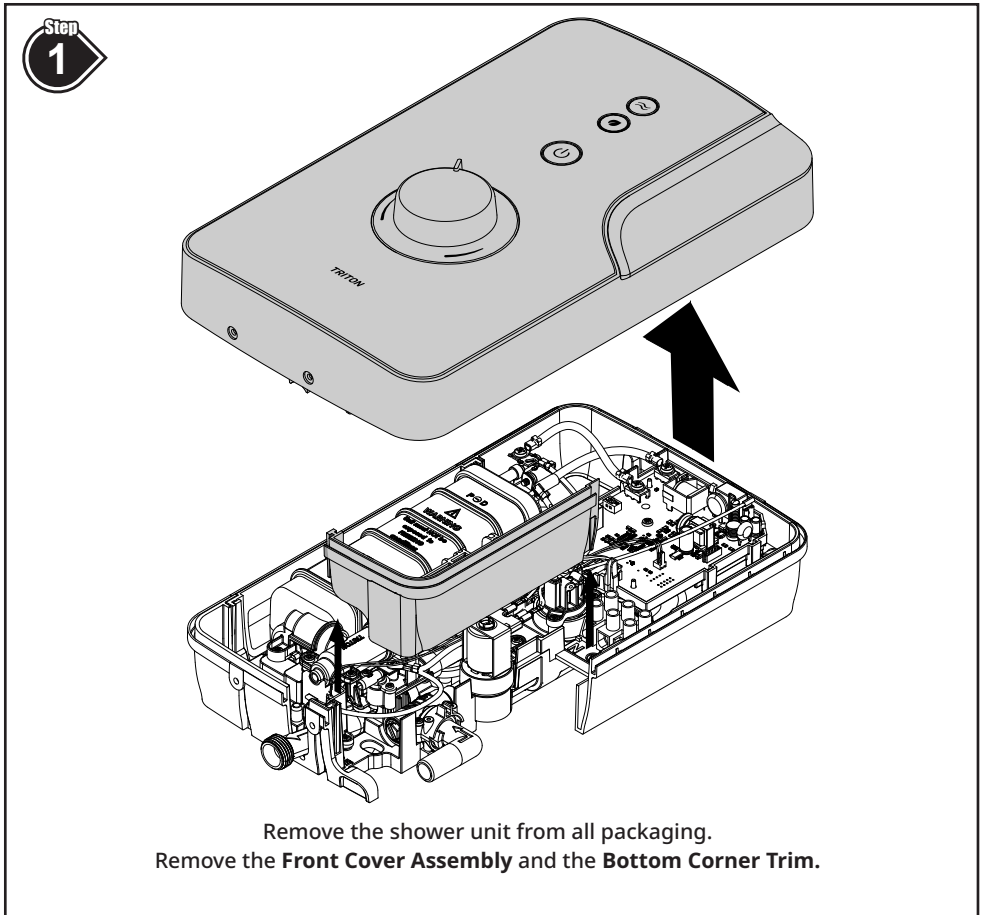

INSTALLATION

Step
2

Determine the Plumbing and Electrical routing into the shower unit.

Rotate the **Inlet Fitting** to suit the required water supply pipe entry position.

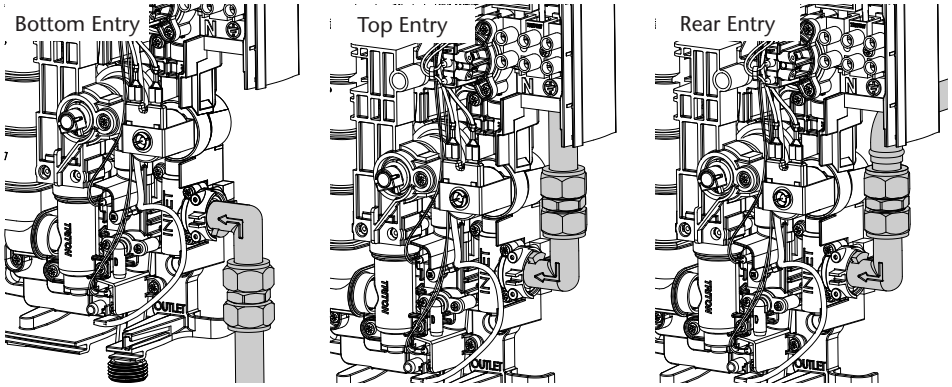

Complete all the plumbing pipe work.

Ensure that any soldering of pipe work is done away from the shower as heat can travel along pipe work and damage components.

IMPORTANT: Before connecting the shower to the plumbing pipe work, flush out the pipe work for approximately 60 seconds to remove any swarf or debris.

Step
3

Step
4

Prepare the shower for fitting to the wall by removing any thinned out sections in the **Bottom Corner Trim** and **Backplate** corresponding to the chosen supply entry position.

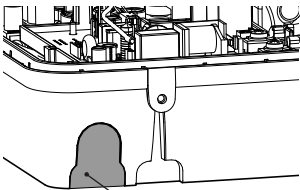

Removable **Pipe & Cable Entry Trim**

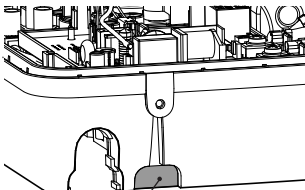

Thinned section on the **Backplate** for alternative top cable entry

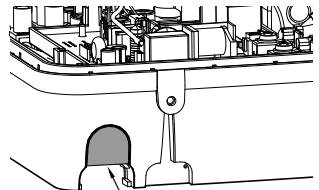

'Snap' off the lower part of the **Pipe & Cable Entry Trim** for alternative top cable entry

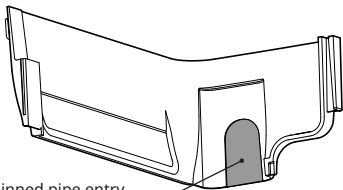

Thinned pipe entry section on the **Bottom Corner Trim**.

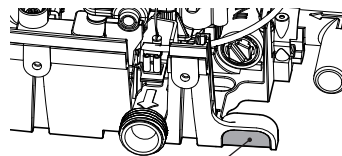

Thinned bottom cable entry section on the **Backplate**.

INSTALLATION

Step
5

Temporarily connect the shower to plumbing pipe work.

Ensure that the unit is level and mark the fixing holes. Use the hole at the top and the 2 holes at the bottom.

Remove the shower from the wall.

Drill the fixing holes.

Use appropriate wall plugs.

Reconnect the shower to plumbing pipe work and secure the shower to the wall using appropriate screws.

IMPORTANT: Ensure the shower is securely fixed to the wall. **DO NOT** use adhesives as a method of securing the appliance to the wall.

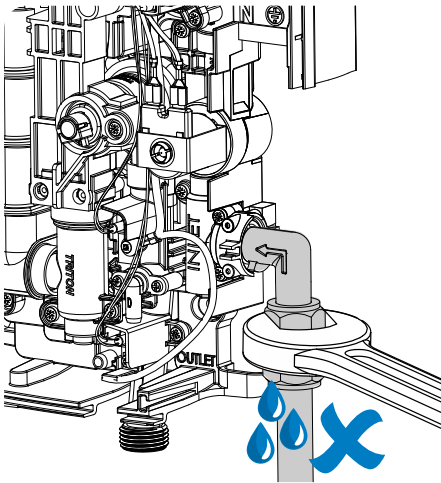
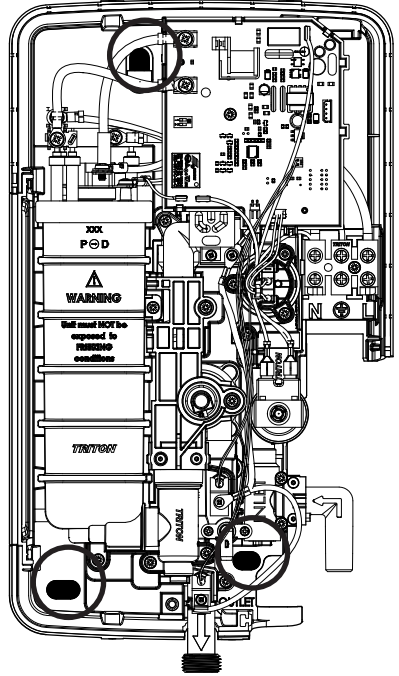

Step
6

Ensure that all pipe connection fittings are tight. **DO NOT** overtighten.

Turn on mains water supply and check the pipe work for any water leakage.

IMPORTANT: Use a suitable sealant to seal around the rear entry pipe work to prevent water entering the wall.

INSTALLATION

Step
7

Route the electrical supply cable into the shower unit.

NOTE: The supply cable must be secured either by routing through conduit, trunking or by embedding in the wall, in accordance with IEE regulations.

Insert the conductors into the appropriate position on the terminal block.

IMPORTANT: DO NOT USE ADDITIONAL TERMINAL BLOCKS/WIRES OTHER THAN THOSE FACTORY FITTED INSIDE THE APPLIANCE. FAILURE TO COMPLY WITH THIS WILL INVALIDATE YOUR GUARANTEE.

NOTE: The earth conductor must be sleeved. The outer sheath of any conductor must be stripped back to a minimum.

Fully tighten the terminal block screws and make sure that no cable insulation is trapped under the screws.

IMPORTANT: Loose connections can result in cable overheating.

DO NOT switch on the electricity supply.

Earth cable (Green/Yellow) to 
Neutral cable (Blue or Black) to **N**
Live cable (Brown or Red) to **L**

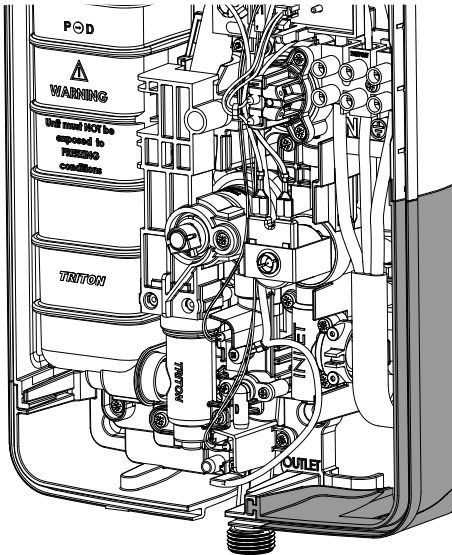
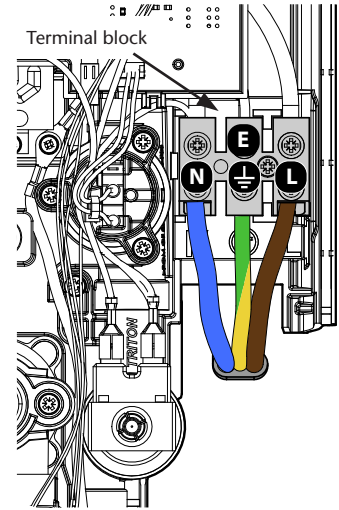

Step
8

Refit the **Bottom Corner Trim**.

INSTALLATION

Step 9

SHOWER SETTINGS

The ENlight® shower has some functionality settings that can be customised to individual user's preference.

A DIP switch mounted on the **Control PCB** allows these settings to be adjusted.

Factory Settings

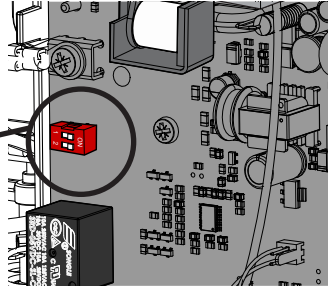
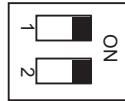

ECO Run Time

This function provides the adjustment in the length of time the shower runs when ECO mode is activated, before it automatically enters phased shutdown.



DIP switch 1 **On** = ECO Run time is 5 minutes (**Factory Setting**)



DIP switch 1 **Off** = ECO Run time is 3 minutes

Shower Run Time

This function provides the adjustment in the length of time the shower runs before it automatically enters phased shutdown.



DIP switch 2 **On** = Shower Run time is 20 minutes (**Factory Setting**)



DIP switch 2 **Off** = Shower Run time is 10 minutes

INSTALLATION

Step
10

COMMISSIONING

Attach the appropriate end of the **Shower Hose** to the shower outlet, using the supplied hose washer seal.

DO NOT overtighten.

Position the other end of the **Shower Hose** to the bath or tray waste.

DO NOT fit the shower head.

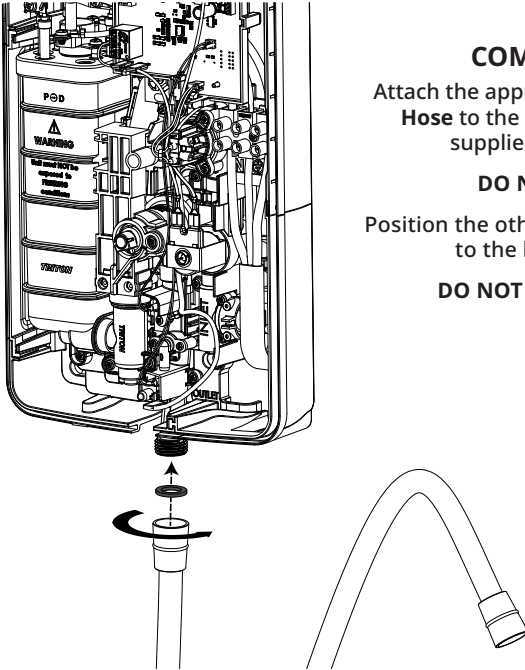

Step
11

During the commissioning process, the electricity supply will need to be switched on, so for safety reasons temporarily fit the cover to the shower.

DO NOT connect the wire from the cover to shower unit PCB.

Minor adjustment of the **Temperature Selector Knob** may be necessary to align with the valve.

Secure the cover in position with one of the retaining screws.

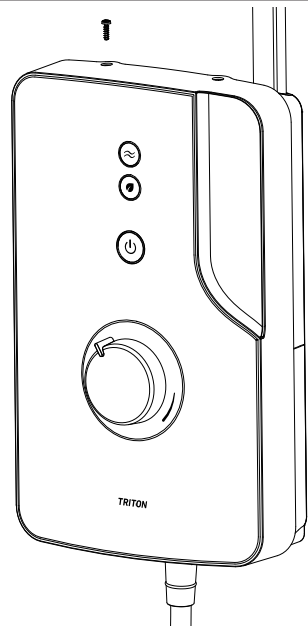

INSTALLATION

Step
12

Turn on the water supply to the shower at the isolating stop valve.
Switch on the electricity supply to the shower at the isolating switch.

Water will start to flow from the shower hose.

Allow water to flow for approximately 60 seconds, this will allow the air to bleed from the installation.

Isolate the electricity to the shower at the isolating switch. The water will cease to flow.

Remove the cover retaining screw and lift off the cover.

NOTE: The shower will only run water for approximately 5 minutes. If a longer time period is required, isolate the electricity supply, wait a few seconds then reapply the electricity supply and water will flow for 5 minutes again.

Step
13

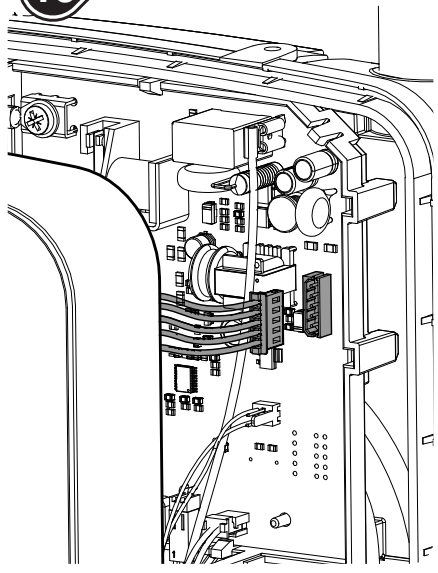

Connect the 5-way cable from the **Front Cover Assembly** to the socket on the **Power PCB**.

NOTE: The cable connector can only be fitted to the socket one way.

Step
14

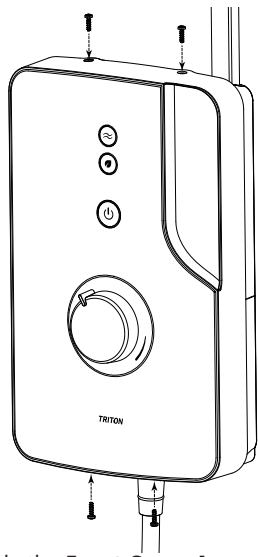

Guide the **Front Cover Assembly** into position.

Ensure the **Temperature Selector Knob** locates correctly onto the valve (minor adjustment of the Temperature Selector Knob may be necessary to align with the valve).

Apply slight pressure to the **Front Cover Assembly** and secure in position with the 4 retaining screws.

Step
15

Install the accessory kit as per the instructions provided with the accessory.

MAINTENANCE

INSTRUCTIONS FOR INSTALLERS AND SERVICE ENGINEERS ONLY

Inlet Filter Maintenance

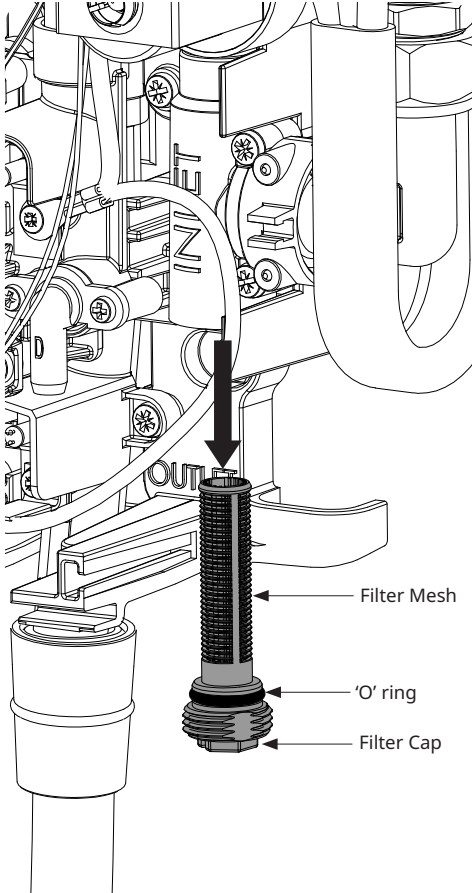

It is recommended that the filter is periodically cleaned in order to maintain the performance of the shower. It is essential that this operation is carried out by a competent person.

Switch off the electricity and water supply at the mains.

The inlet filter is situated inside the water inlet fitting.

To gain access to the filter remove the **Front Cover Assembly** and **Bottom Corner Trim**. Unscrew the inlet filter cap on the water inlet fitting.

Inspect the O-ring for damage when the filter is removed. Do not over tighten the filter cap on reassembly.

When cleaning the filter mesh, do not use a sharp object as it will cause damage. It is preferable to use an old toothbrush or similar.

FAULT DIAGNOSTICS

IMPORTANT: Isolate the electricity supply and remove the circuit fuse before attempting any fault finding inside the unit.

Problem	Cause	Action
Shower inoperable, (Standby LED's not illuminated).	Interrupted power supply.	a) Blown fuse or circuit breaker. Check supply. Renew or reset fuse or circuit breaker. If it fails again, consult a qualified electrician.
		b) Power cut? Check other appliances and if necessary, contact local Electricity Supply Co.
	Thermal cut-out operated.	The thermal cut-out safety device has operated. Have the unit checked by a suitably qualified service engineer or contact Customer Experience.
	Unit malfunction.	Have the unit checked by a suitably qualified service engineer or contact Customer Experience.
Showering water too hot.	Temperature control set incorrectly.	Adjust the temperature control to the preferred setting.
	Unit malfunction.	Have the unit checked by a suitably qualified service engineer or contact Customer Experience.
Showering water too cool.	Temperature control set incorrectly.	Adjust the temperature control to the preferred setting.
	Heater elements have been turned off.	Start the shower using the Start/Stop button, or if the shower is already running, press the Heater Button to switch the elements on, 'Heaters On' will show on the display.
	'Over Temperature' is shown on the display	Wait for the shower to reset. If problem occurs frequently have the unit checked by a suitably qualified service engineer or contact Customer Experience.
	Unit malfunction.	Have the unit checked by a suitably qualified service engineer or contact Customer Experience.
Water will not stop flowing from unit unless switched off at isolating switch.	5-way cable from the front cover assembly is loose or not connected to the Power PCB.	Isolate the electricity supply, remove the front cover assembly and follow 'Step 13' in the installation process.
	'Fault 1' is shown on the display.	Have the unit checked by a suitably qualified service engineer or contact Customer Experience.
Shower stops flowing water during showering, and 'Fault 6 or 7' is shown on the display.	Unit malfunction.	Have the unit checked by a suitably qualified service engineer or contact Customer Experience.

FAULT DIAGNOSTICS

IMPORTANT: Isolate the electricity supply and remove the circuit fuse before attempting any fault finding inside the unit.

Problem	Cause	Action
'Low Flow' is shown on the display	Inadequate incoming water flow or pressure	Check that the water supply to the shower is adequate for the shower, refer to the Specification section of the Installer Guide.
		Check and clean Inlet Filter, refer to Inlet Filter Maintenance section of the Installer Guide.
Shower inoperable, (Standby LED's illuminated).	'Fault 2' is shown on the display when Start/Stop button is pressed.	Internal shower fault, make note of fault code and contact Triton Customer Experience.
	'Fault 3' is shown on the display when Start/Stop button is pressed.	Internal shower fault, make note of fault code and contact Triton Customer Experience.
	'Fault 4' is shown on the display when Start/Stop button is pressed.	Internal shower fault, make note of fault code and contact Triton Customer Experience.
	'Fault 5' is shown on the display when Start/Stop button is pressed.	Internal shower fault, make note of fault code and contact Triton Customer Experience.
	'Fault 8' is shown on the display when Start/Stop button is pressed.	Internal shower fault, make note of fault code and contact Triton Customer Experience.
Pressure relief device has operated (water ejected from PRD tube).	Blocked shower head.	Clean sprayplate and then fit a new PRD.
	Damaged/blocked flexible shower hose.	Check for free passage through the hose. Replace hose if necessary and then fit a new PRD.
	Shower head not removed while commissioning.	Fit a new PRD. Commission the unit with the shower head removed.

NOTE: Identify cause of operation before fitting new PRD unit. When fitting a new PRD, follow the Commissioning procedure.
It is advised all electrical maintenance/repairs to the shower should be carried out by a suitably qualified person.

In the unlikely event of a fault occurring please contact Triton Customer Experience. DO NOT remove the shower from the installation.

To purchase a genuine Triton spare part for your product, please visit **www.tritonshowers.co.uk/spares** for product codes and prices. Alternatively please call our Customer Experience team on **024 7637 2222** to order direct. Please have your model name available.

UK SERVICE POLICY

In the event of a product fault or complaint occurring, the following procedure should be followed:

DO NOT REMOVE THE PRODUCT

1. Telephone Customer Experience on **024 7637 2222** having available your details including post code, the model number and power rating of the product, together with the date of purchase and, where applicable, details of the particular fault.
2. If required, the Customer Experience Advisor will arrange for a qualified engineer to call.
3. All products attended to by a Triton service engineer must be installed in full accordance with the Triton installation guide applicable to the product; this can be downloaded free at www.tritonshowers.co.uk/guides.
4. Our engineer will require local parking and if a permit is required, this must be available to the engineer on arrival at the call.
5. If loft access is required for isolation or to complete a repair, the loft must have a fixed access ladder and be boarded, with appropriate lighting from the access point to and around the repair area.
6. It is essential that you or an appointed representative, who must be over 18 years of age, is present for the duration of the service engineer's visit. If the product is in guarantee you must provide proof of purchase.
7. Where a call under the terms of guarantee has been booked and the failure is not product related (i.e. scaling and furring, incorrect water pressure, pressure relief device operation or electrical/plumbing installation fault) a charge will be made. A charge will also be issued if nobody is at the property when the service engineer calls or adequate parking/permit is not available.
8. If the product is no longer covered by the guarantee an up-front fixed fee will be charged before the site visit.
9. Your receipt must be retained as proof of purchase. Should proof of purchase not be available on an 'in-guarantee' call, or should the service engineer find that the product is no longer under guarantee, the engineer will charge the same fixed price and will request payment prior to departing. If payment is not made on the day an administration charge will be added to the fixed charge.
10. If a debt is outstanding from a previous visit, or from any other Triton purchase, Triton reserves the right to withhold service until the debt has been settled.
11. Triton takes the health, safety and wellbeing of its employees very seriously and expects customers to treat all staff members with respect. Should any employee feel threatened or receive abuse, either verbally or physically, Triton reserves the right to withhold service.

Replacement Parts Policy

In line with AMDEA guidelines, Triton retains functional spares for as long as there is a market for them and in most cases, well beyond. Due to the vast array of product types, the life cycle of products can vary and therefore so can the length of time parts can be supplied. Spare parts can be ordered via our online spare parts store or by telephoning Triton Customer Experience team on **024 7637 2222**. Payment should be made by credit / debit card (excluding American Express or Diners Card). Payment can also be made by pre-payment of a pro-forma invoice, by cheque or postal order.

Telephone orders are based on information given during the call. Before contacting Triton, please verify your requirements using the Triton website or your professional installer. Triton cannot accept liability for incorrect part identification.

TRITON UK STANDARD GUARANTEE

This guarantee applies only to products installed within the United Kingdom and does not apply to products used commercially. This guarantee does not affect your statutory rights.

With the exception of accessories, Triton guarantee the product against all manufacturing defects for a period of **2 years** (for domestic use only) from the date of purchase, provided that it has been installed by a competent person in full accordance with the fitting instructions.

All accessories such as shower heads, hoses and riser rails carry a **1 year** parts only guarantee against manufacturing defects.

Any part found to be defective during this guarantee period we undertake to repair or replace at our option without charge, so long as it has been properly maintained and operated in accordance with the operating instructions and has not been subject to misuse or damage. This product must not be taken apart, modified or repaired except by a person authorised by Triton.

What is not covered:

1. Breakdown due to:
 - a) use other than domestic use by the property occupants;
 - b) wilful act or neglect;
 - c) any malfunction resulting from the incorrect use or quality of electricity, gas or water or incorrect setting of controls;
 - d) failure to install in accordance with this installation guide.
2. Claims for missing parts once the product has been installed.
3. Repair costs for damage caused by foreign objects or substances.
4. Total loss of the product due to non-availability of parts.
5. Compensation for loss of use of the product or consequential loss of any kind.
6. Call out charges due to an abortive visit or where no fault has been found with the appliance.
7. The cost of repair or replacement of isolating switches, electrical cable, fuses and/or circuit breakers or any other accessories installed at the same time. Replacement of a Pressure Relief Device that only activates when the shower outlet is blocked is also excluded.
8. The cost of routine maintenance, adjustments, overhaul modifications or loss or damage arising therefrom, including the cost of repairing damage, breakdown, malfunction caused by corrosion, furring, frost or exposure to freezing conditions.
9. Callout charges where the water supply cannot be isolated, this includes consequential losses arising from unserviceable supply valves, or inaccessible product or valves located in a loft space without suitable access.

For the latest Terms & Conditions please see:

www.tritonshowers.co.uk/terms

PLEASE NOTE PRODUCT REGISTRATION IS ONLY AVAILABLE TO UNITS PURCHASED & INSTALLED IN THE UK

Triton Showers
Triton Road
Nuneaton
Warwickshire, CV11 4NR

Triton is a division of Norcros Group (Holdings) Limited

Triton reserve the right to change product specification without prior notice. E&OE. © TRITON SHOWERS 2026

Customer Experience: **024 7637 2222**
Trade Installer Hotline: **024 7637 8344**
www.tritonshowers.co.uk
E-mail: CXsupport@tritonshowers.co.uk
E-mail: technical@tritonshowers.co.uk