

ADAM 2 Riser rail assembly

88900080

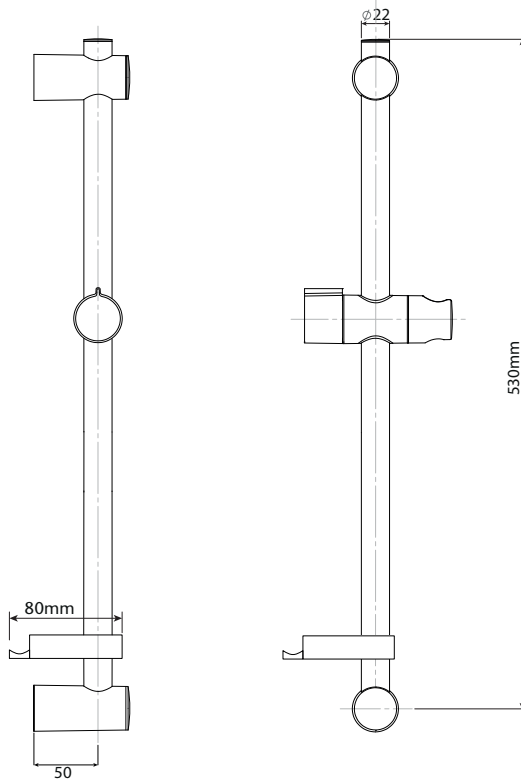

All dimensions listed regarding the product and installation are approximate.
Please read the fitting instructions before proceeding.

Installation Instructions

TRITON ALWAYS RECOMMEND THE USE OF GENUINE TRITON ACCESSORIES FOR USE WITH A TRITON SHOWER.
FAILURE TO USE GENUINE TRITON PARTS MAY INVALIDATE YOUR GUARANTEE.

INSTALLERS PLEASE NOTE THESE INSTRUCTIONS ARE TO BE LEFT WITH THE USER

FITTING THE ADAM RISER RAIL ASSEMBLY

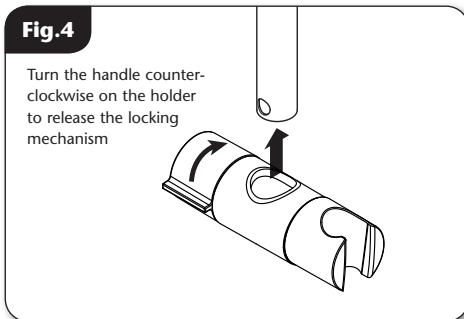
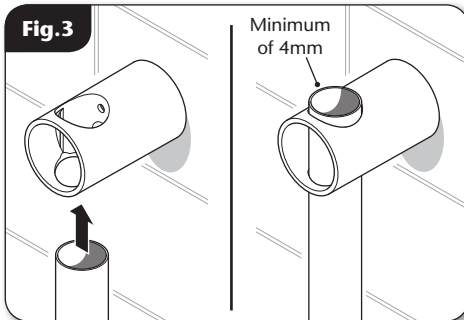
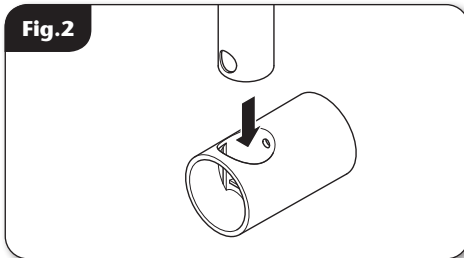
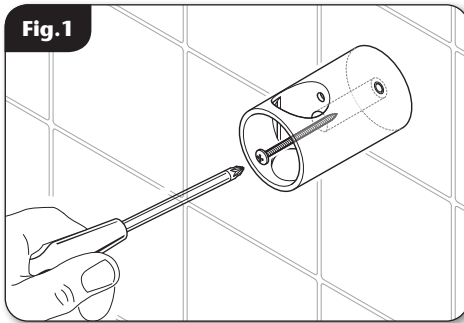

WARNING!

Check there are no hidden cables or pipes before drilling holes for wall plugs. Use great care when using power tools near water. The use of a residual current device (RCD) is recommended when using power tools.

Decide on the position for the rail on the wall within the shower area and proceed as follows.

Offer the upper bracket to the wall. Position the bracket and mark the centre hole. Remove the bracket then drill and plug the wall.

An appropriate drill bit should be used. If the wall is brick, plasterboard or a soft building block, appropriate wall plugs and screws should be fitted.

Replace the bracket to the wall and secure in place (**Fig.1**).

Fit the bottom bracket onto the riser rail. The end of the riser rail with the two holes in it should be the end that is inserted (**fig.2**).

Slide the riser rail through the opening in the upper bracket (**fig.3**). The riser rail should be a minimum of 4mm proud of the upper bracket. Make sure the rail is vertical then mark the centre hole for the bottom bracket. Remove the rail and lower bracket and drill and plug the wall.

Fit the shower head holder onto the riser rail. Turn the handle counter-clockwise on the holder to release the locking mechanism, then slide the holder onto the rail (**fig.4**). To secure the holder in place, simply turn the handle clockwise.

FITTING THE ADAM RISER RAIL ASSEMBLY

Slide the hose retainer onto the bottom of the riser rail, below the shower head holder (**fig.5**).

Refit the bottom bracket to the riser rail and fit the rail through the upper bracket.

Note: The larger of the two holes in the bottom of the riser rail should be facing outwards when the holes are aligned with the middle fixing hole in the bracket.

Secure the bottom bracket to the wall.

Note: The screw should pass through the larger hole in the base of the riser rail (**fig.6**) and come to rest against the inner of the riser rail to stop it from turning within the bracket.

Fit the end caps onto both brackets. The end caps will only fit one way. Fit the riser rail trim to the top of the rail.

FITTING THE HOSE AND SHOWER HEAD*

Feed the flexible hose through the opening in the hose retainer. **The hose retainer MUST be used to comply with Water Regulations (fig.7).**

Screw the flexible hose to the shower outlet and shower head, making sure the supplied washers are in place at both ends of the flexible hose (**fig.8**).

Place the shower head into the holder and check that it fits correctly (**fig.9**).

Note: The holder is slightly tapered and the shower head and hose will only fit from one direction.

IMPORTANT: It is the conical end of the hose which grips into the holder. The shower head will not fit in the holder without the hose attached.

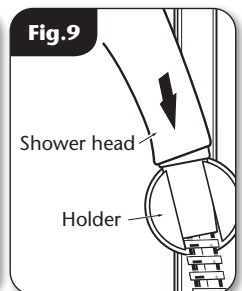
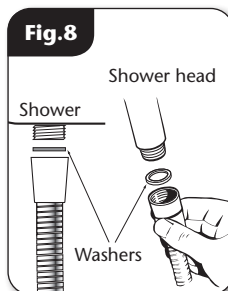
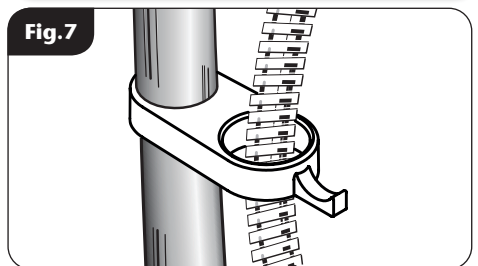
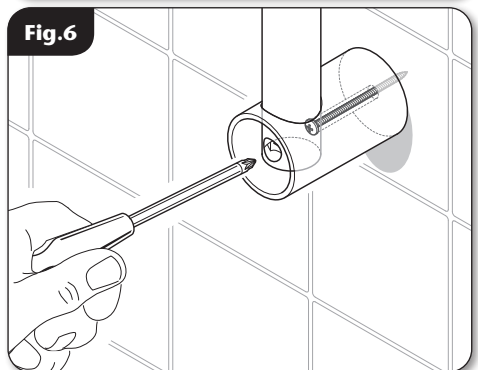
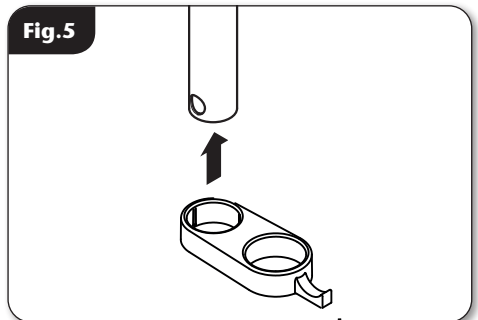

*Not supplied unless otherwise stated.

SPARE PARTS

Ref. Description	Part number
------------------	-------------

- | | |
|--|----------|
| – Kit chrome (without riser rail)..... | 88900080 |
| A Brackets & trims - pair | 22013360 |
| B Trim - single | 22013380 |
| C Riser rail | 88800043 |
| D Shower head holder | 22013400 |
| E Hose retainer - Clear..... | 22013450 |

Flexible hoses available in the following sizes:

- 1.25m in white and chrome
- 1.75m in chrome only
- 2.00m in chrome only

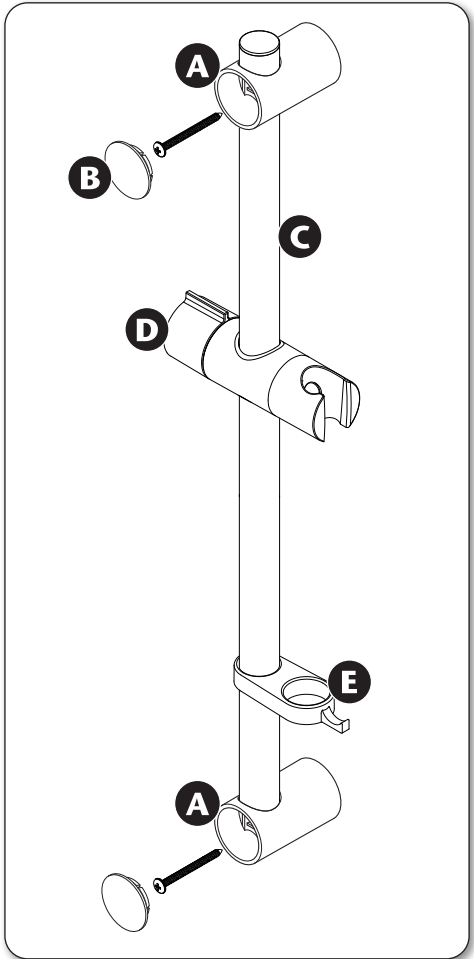

Please refer to shower installation and operating instructions for service details.