

TRITON

DENE ECO Bar Mixer

**REGISTER ONLINE
ENTER A PRIZE DRAW**

**WIN
£100**

LOVE2SHOP VOUCHERS

VISIT OUR WEBSITE TODAY

TRITONSHOWERS.CO.UK/REGISTER

*PRODUCT REGISTRATION IS ONLY AVAILABLE
TO UNITS PURCHASED & INSTALLED IN THE UK*

FOR YOUR SERVICE REFERENCE

NOTE DOWN THE PRODUCT CODE BELOW
(FROM THE FRONT OR TOP OF THE BOX)

ALTERNATIVELY REGISTER BY TEL: 024 7637 8321



86004420

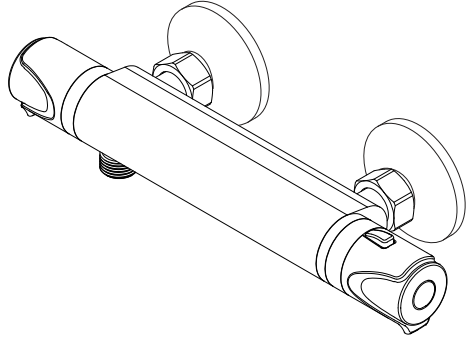

ECO STATEMENT

**This product has been fitted
with a flow regulator to
deliver a maximum flow
rate of 6 litres per minute.**

IMPORTANT SAFETY ADVICE

The shower head and hose supplied with this product are a safety critical part of your shower. Failure to use genuine Triton parts may cause injury and invalidate your guarantee.

INSTALLATION AND OPERATING INSTRUCTIONS

Please read this book thoroughly and familiarise yourself with all instructions before commencing installation and keep it for future reference.

The mixer shower installation **MUST** be carried out by a suitably qualified person, **in the sequence of this instruction book.**

CONTENTS	Page
MAIN COMPONENTS.....	3
DIMENSIONS	4
INTRODUCTION.....	5 - 6
TYPICAL DOMESTIC INSTALLATIONS.....	7 - 9
PREPARING THE SHOWER	10
SITING OF THE SHOWER	10
BRACKET INSTALLATION	11 - 15
LEAK TESTING THE SHOWER	15
COMMISSIONING.....	16
FLOW REGULATION.....	16
TEMPERATURE ADJUSTMENT	17
RECOMMENDED OUTLET TEMPERATURES	17
OPERATING THE SHOWER	18
SPARE PARTS	19
TMV2 REQUIREMENTS (12 MONTHLY VERIFICATION).....	20
APPROVALS	20
MAINTENANCE	21
FAULT FINDING.....	22 - 23
GUARANTEE, SERVICE POLICY, ETC.	rear cover

INSTALLERS PLEASE NOTE THESE INSTRUCTIONS ARE TO BE LEFT WITH THE USER

To check the product suitability for commercial and multiple installations, please contact Triton's specification advisory service before installation. Please see back of book for contact information.

MAIN COMPONENTS

Fig.1

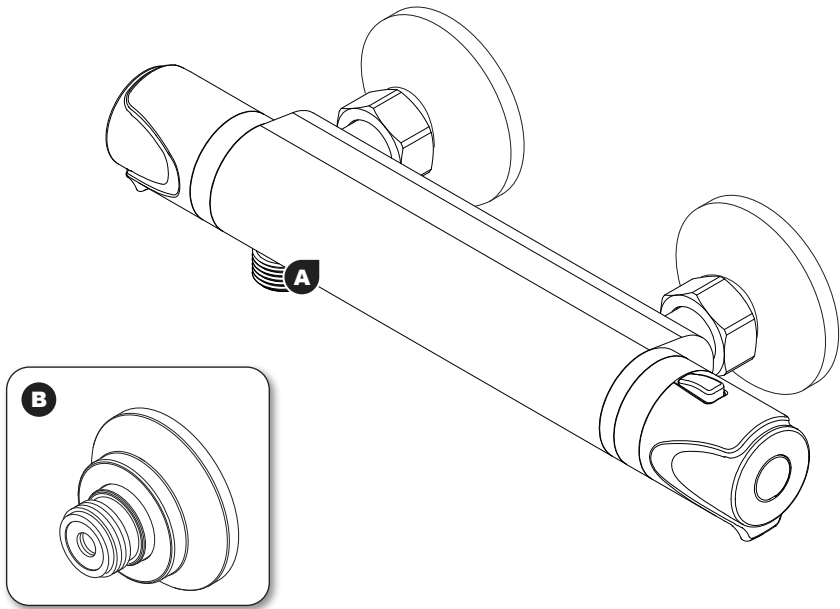

- A.** Thermostatic bar mixer valve
- B.** Push-fit connector x2 (with trims)

Bar Mixer Shower

DIMENSIONS

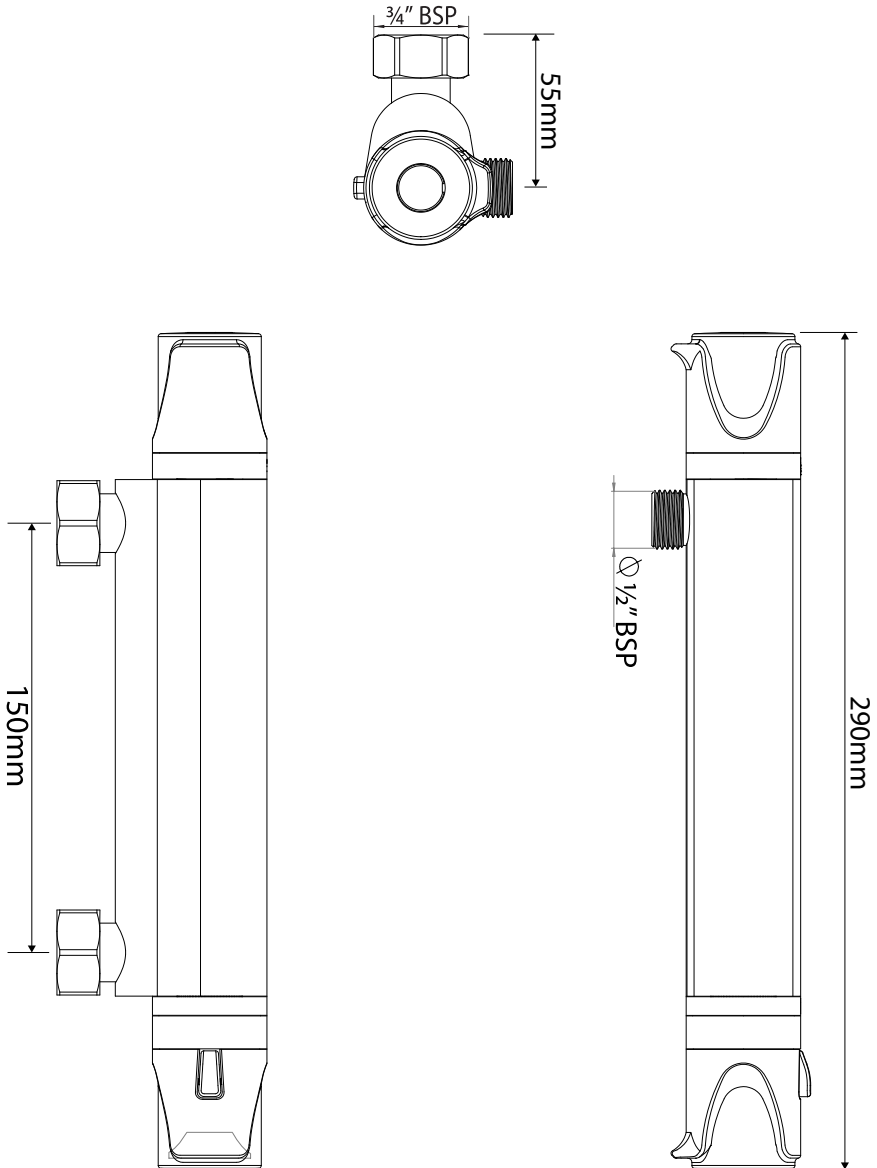

All dimensions listed in this fitting book regarding the product and installation are approximate.

INTRODUCTION

This book contains all the necessary fitting and operating instructions for your mixer shower. Please read them carefully and read through the whole of this book before beginning your installation.

The shower installation must be carried out by a suitably competent person and in sequence of this instruction book.

Care taken during the installation will give a long and trouble free life from your mixer shower.

SITE REQUIREMENTS

The installation must be in accordance with water supply (water fittings) regulation 1999 and/or local Bylaws.

Water Pressure Requirements

Running water pressure:

Low pressure*	- 0.1 bar min. 1.0 bar max.
High pressure	- 0.5 bar min. 5.0 bar max.

Maximum static water pressure:

Low & High pressure	- 10 bar
---------------------	----------

*This mixer shower is designed for high pressure systems found in the UK but can be installed with low pressure gravity water systems with reduced flow rates.

For effective operation of the internal seals, the maximum static pressure must not be exceeded.

Pressure Reducing Valve

On sites where the running pressure is above 5 bar, the use of a suitably sized pressure reducing valve fitted in the cold mains supply pipework can provide nominally equal pressures at the mixer shower.

Water Minimum Flow Rate

For best performance within the specified running pressure range a minimum flow of 8 litres per minute should be available to both inlets.

Water Temperature Requirements

Recommended maximum:	= 65°C
Minimum hot water temperature:	= 55°C
Maximum cold water temperature:	= 25°C

NOTE: Valves operating outside these conditions cannot be guaranteed by the Scheme to operate as Type 2 valves.

A stored water temperature of 60°C is considered sufficient to meet all normal requirements and will minimise the effects of scale in hard water areas.

Water Temperature Adjustment and Thermal Safety

The mixed water temperature can be adjusted from cold through to a top limit which must be preset during installation with full anti-scald protection throughout the range (35°C to 40°C) providing the hot water temperature at the inlet remains 10°C above the outlet temperature.

Should there be a loss of flow to either incoming supply then water from the shower will stop or be reduced until both supplies are restored.

SAFETY WARNINGS

- DO NOT** choose a position where the mixer shower could become frozen.
- DO NOT** connect this mixer shower to any form of tap or fitting not recommended by the manufacturer.
- DO NOT** allow the inlet pressure or flow rates to operate outside the guidelines laid out in Site Requirements.
- DO NOT** connect the mixer shower to a gravity hot supply and a mains cold supply or vice versa.

PLUMBING REQUIREMENTS

DO NOT use jointing compounds on any pipe fittings for the installation.

DO NOT solder fittings near the mixer shower as heat can transfer along the pipework and damage the shower.

DO NOT subject the mixer shower to a water temperature above 80°C during installation, use, maintenance or disinfection.

IMPORTANT:

- The layout and sizing of pipework **MUST** be such that nominally equal inlet supply pressures are achieved and the effects of other draw-offs are minimised.
- The pipework should be installed such that other taps and appliances being operated elsewhere on the premises do not significantly affect the flow
- When connecting pipework avoid using tight 90° elbows; swept or formed bends will give the best performance.
- The hot water pipe entry **MUST** be made to the left-hand side inlet, marked HOT, 'H' or with a red/orange label.
- Suitable isolating valves (complying with Water Regulations and Bylaws) **MUST** be fitted on the hot and cold water supplies to the shower as an independent means of isolating the water supplies should maintenance or servicing be necessary; position as close as is practicable to the water supply inlets of the mixer shower. If this isolator is fitted in a loft space, the loft must have a fixed access ladder and be boarded, with appropriate lighting from the access point to the isolator.
- It is preferable to flush the pipework to clear the system of debris and check for leaks before connecting to the mixer.
- The mixer inlets contain removable filters that may become blocked if debris is not flushed through before fitting.

Commercial Applications

- It is recommended that for all commercial applications, easily accessible, in-line filters are used to aid maintenance.

Hard Water Areas

- a. If it is intended to operate the shower in areas of hard water (above 200-ppm temporary hardness), a scale inhibitor may have to be fitted. For advice on the scale inhibitor, please contact Customer Experience.
- b. For best performance the showerhead **MUST** be regularly cleaned to remove scale and debris.

WATER SYSTEM REQUIREMENTS

This mixer shower is suitable for:

- Gravity water systems
- Pumped gravity systems
- Fully modulating type combination boilers
- Multi-point hot water heaters
- Thermal storage
- Unvented systems

When installing this mixer shower with a combination or multi-point boiler, it may be necessary to install flow regulation.

Check that the appliance is capable of delivering hot water at a minimum switch-on flow rate of 3 litres per minute. At flow rates between 3 and 8 litres per minute, the appliance **MUST** be capable of raising the water temperature to 52°C minimum.

Water temperature at the inlet of the mixer shower **MUST** remain relatively constant when flow rate adjustments are made - refer to the appliance operating manual to confirm compatibility with this mixer shower.

Where thermal store systems and instantaneous gas water heaters are used, if excessive draw-off takes place the appliance may not be able to maintain an adequate output temperature. This could result in the shower temperature becoming noticeably cooler.

Flow regulators can be fitted with high-pressure water systems to reduce flow rate and assist economy.

The hot supply temperature **MUST** remain a minimum of 10°C hotter than the required blend temperature for optimum performance.

***Fig.2**

*Diagrammatic view – not to scale.
For illustration purposes only.

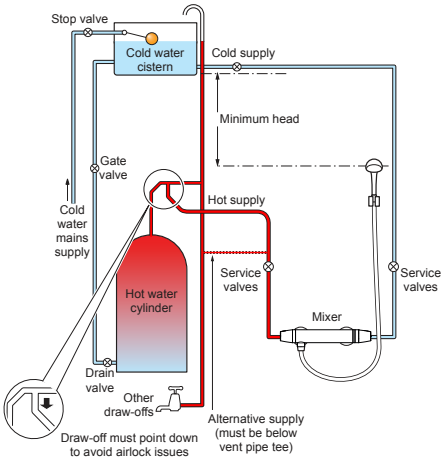

TYPICAL DOMESTIC INSTALLATIONS

Domestic Gravity Fed Systems (fig.2)

The mixer shower control **MUST** be fed from a cold water cistern and hot water cylinder providing nominally equal pressures. There **MUST** be a minimum of one metre head of water. The minimum head distance is measured from the base of the cold water cistern to top of the showerhead.

If valves are gravity fed then supply pressure should be verified to ensure conditions of use are appropriate for the valve.

***Fig.3**

*Diagrammatic view – not to scale.
For illustration purposes only.

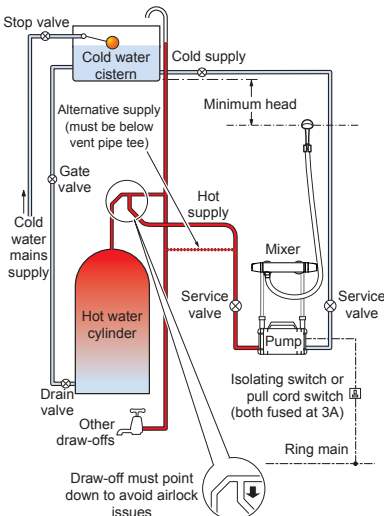

Pumped Gravity Fed Systems (fig.3)

The mixer shower **MUST** be fed from a cold water cistern and hot water cylinder providing nominally equal pressures.

The mixer shower may be used with a gravity fed system with a pump to boost pressures as shown; please refer to the pump installation guide to establish the minimum head requirements for automatic operation of the pump.

Bar Mixer Shower

Instantaneous Gas-heated Systems, e.g. combination boilers (fig.4)

The mixer shower **MUST** be installed with a multi-point gas water heater or combination boiler of a fully modulating design i.e. to maintain relatively stable hot water temperatures.

A drop tight pressure reducing valve **MUST** be fitted if the supply pressures exceed 5 bar running.

An expansion vessel **MAY** be fitted, and regularly maintained, to prevent the mixer shower being damaged by excess pressures. This may already be installed within the boiler (check with manufacturer) and is in addition to the normally larger central heating expansion vessel.

*Fig.4

*Diagrammatic view – not to scale. For illustration purposes only.

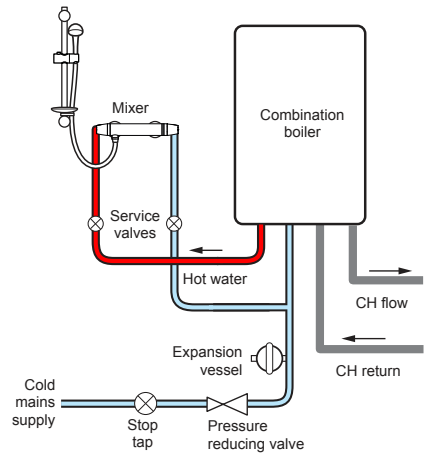

Unvented Mains Pressure Systems (fig.5)

The mixer shower can be installed with an unvented, stored hot water cylinder.

For systems with no cold water take off after the appliance reducing valve, it will be necessary to fit an additional drop tight pressure reducing valve when the mains pressure is over 5 bar. The drop tight pressure reducing valve **MUST** be set at the same value as the unvented package pressure reducing valve.

NOTE: An additional expansion vessel may be required if a second pressure reducing valve is installed. This does not apply to packages with a cold take off after the pressure reducing valve to the cylinder.

*Fig.5

*Diagrammatic view – not to scale. For illustration purposes only.

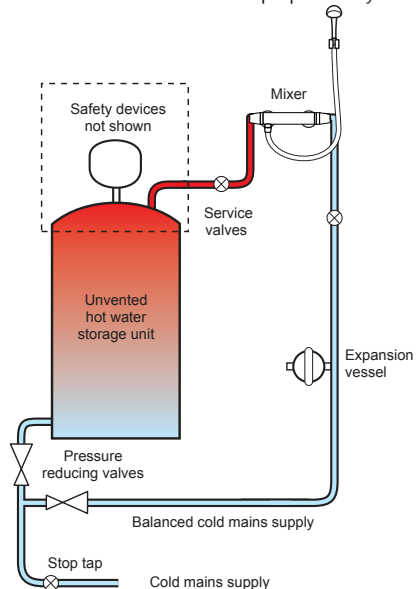

***Fig.6**

*Diagrammatic view – not to scale.
For illustration purposes only.

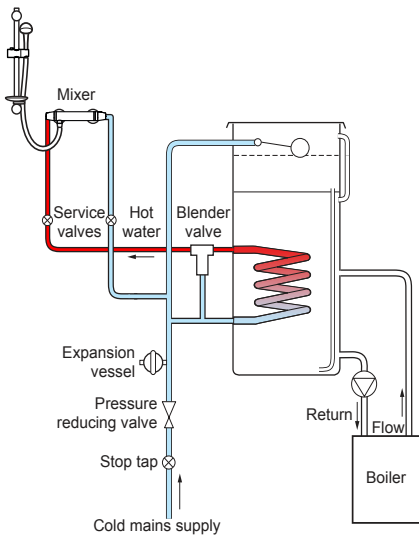

Mains pressurised thermal store systems (fig.6)

Packages of this type, fitted with a tempering valve (blender valve) can be used. A drop tight pressure reducing valve **MUST** be fitted if the supply pressures exceed 5 bar running.

An expansion vessel **MUST** be fitted and regularly maintained to ensure the unit is not damaged by excess pressures. This may already be installed externally or internally within the thermal store (check with thermal store manufacturer).

INSTALLATION

PREPARING THE SHOWER

Check the contents to make sure all items are present.

Before starting, make sure all of the openings on the valve are carefully covered to stop ingress of any debris etc, while routing the supply pipework.

The shower valve is suitable for exposed installation onto solid wall, a stud partition wall, dry lined wall or fixing to a laminate cubicle or panel.

SITING OF THE SHOWER & ACCESSORIES

Refer to **fig.7** for correct siting of the shower.

The mixer shower should be positioned as detailed, with all controls within comfortable reach of the user.

The accessories (showerhead, riser rail and/or fixed showerhead) can be positioned above or to either side of the shower.

The mixer shower must be installed in a position that allows for easy access for future maintenance and commissioning.

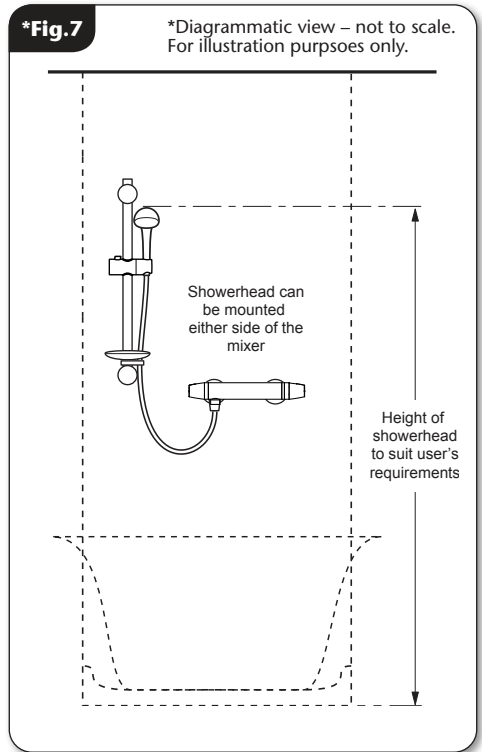
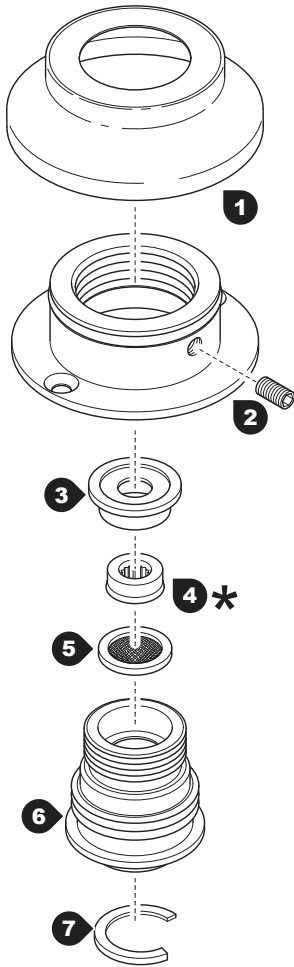

Fig.8



1. Cover trim x2
2. Mounting plate and grub screw x2
3. Plastic seal x2
4. Flow regulator x2
5. Filter x2
6. Push-fit connector x2
7. Locking clip x2

*If supplied

BRACKET INSTALLATION

This guide contains all the necessary fitting instructions for your (built-in pipework, push-fit connector) bar mixer bracket. The bracket has been designed to be surface mounted, using 15mm pipework and can be used with bar mixers or bath shower mixers with 3/4" BSP fixings.

Please read the instructions carefully.

Read through the whole of this guide before beginning installation.

The bracket installation must be carried out by a suitably competent person and in the sequence of the instruction book.

Care taken during the installation will provide trouble free operation from the bracket.

SAFETY WARNINGS

- a. Layout and sizing of pipework must be such that when other services are used, pressures at the mixer control inlets do not fall below the recommended minimum.
- b. **DO NOT choose a position where the mixer shower could become frozen.**
- c. **DO NOT connect to any form of tap or fitting not recommended by the manufacturer.**
- d. Conveniently situated service valves in each inlet supply must be fitted as an independent method of isolating the bracket should maintenance or servicing be necessary.

Replacement parts can be ordered from Customer Experience.

⚠ WARNING ⚠

The threads of number 6 (push-fit connector) are sharp. The use of gloves or a suitable rag is recommended when handling the item, to avoid being cut by the threads.

WARNING!

Check there are no hidden cables or pipes before drilling holes for wall plugs. Use great care when using power tools near water. The use of a residual current device (RCD) is recommended.

PRIMARY CONSIDERATIONS

Please consider the following points before beginning the installation:

- The brackets must be mounted onto a surface that is both solid and strong enough to support the final assembly of brackets and bar mixer.
- The push-fit connectors can be used with either 15mm copper or plastic pipework.
DO NOT use chrome plated pipework.
- When installed, the pipework should not be fixed within one metre of the bracket.
- When installed, the pipework must be backed by a solid structure. When fitting the push-fit connectors, the pipework will need to resist the applied force.
- Clearance should be provided behind the finished wall (at the point at which the pipework exits the wall) to allow the pipe to be moved in and out of the wall by a minimum distance of 4mm. This distance should be a measure of total travel of the pipe between a solid structure and the rear of the finished wall. This clearance will allow the pipework to move when the mounting plate is assembled onto the push-fit connector, ensuring that the seal to the pipework remains undisturbed (**fig.10**).
- The pipes that enter the brackets should be cut using a suitable pipe cutter and deburred.
DO NOT use a hacksaw or other cutting tool that may damage the outer surface of the pipework as this may prevent a good seal to the push-fit connector.

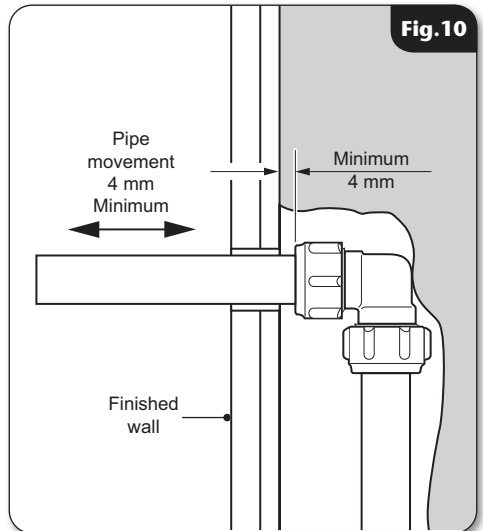
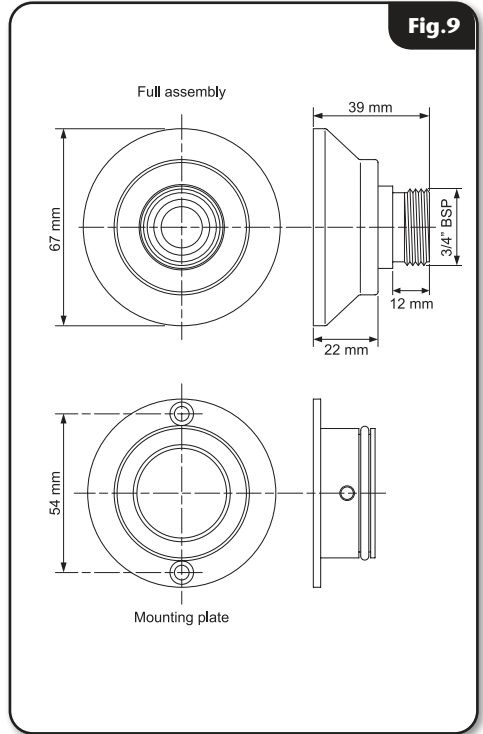

Bar Mixer Shower

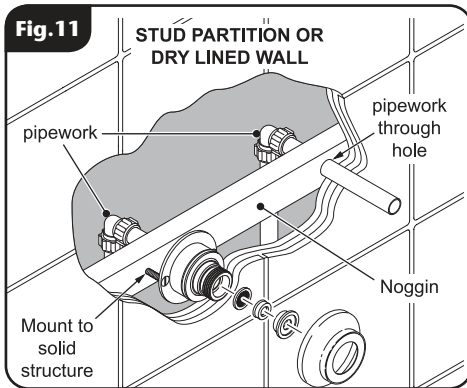

IMPORTANT: These bar mixer brackets are designed to be mounted onto a solid structure. If installing to a stud partition wall, dry lined wall or similar, it is recommended that the brackets are secured to the studs or noggins. In this case, the pipework to the brackets should pass through the support studs or noggins via a suitably sized hole (**fig.11**).

Decide upon the mounting position of the brackets on the wall and mark the centres.

Check the mounting marks are level and that the distance between them is equal to the distance between the bar mixer inlet centres (**fig.12**).

Mark the route of the pipework to the brackets.

Remove the plaster and brickwork or plasterboard to the depth required and chase out additional areas of the wall to allow for the incoming pipework. Make sure that enough solid structure of wall remains around the chasing to accommodate the mounting plate wall plugs and screws (**fig.13**).

Complete the pipework to the bracket mounting points. Leave an excess of pipe protruding out of the wall of approximately 60mm as measured from the face of the finished wall or tiles (**fig.14**).

Flush the pipework through to remove any debris. Check for leaks and remedy as necessary.

Make good the wall and tiles. Make sure that the pipes exiting the wall are free and can move in and out of the wall by a minimum distance of 4mm (**fig.10**).

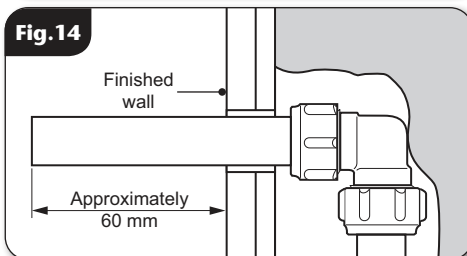
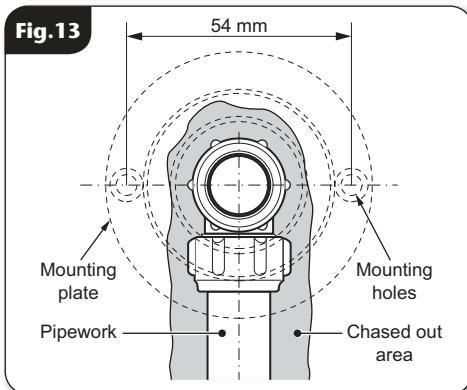
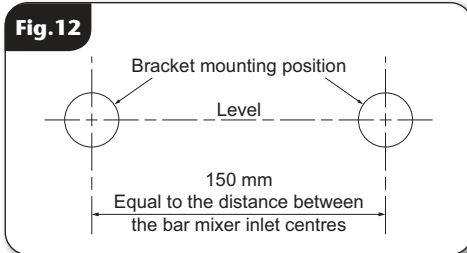

Push each pipe into the wall until it stops against the depth of chasing. Measure 29mm from the face of the finished wall or tiles and mark the pipe.

Using a pipe cutter, cut the pipe at the 29mm mark and deburr.

IMPORTANT: When the pipework is at rest against the depth of chasing the length of pipe protruding from the wall should be between 30mm MAXIMUM and 28mm MINIMUM from the face of the finished wall or tiles (fig.15).

Make sure the outer surface of the pipes are clean and free of any debris or damage. Clean the surface if necessary.

IMPORTANT: Press a push-fit connector onto each pipe until the pipe is pushed past the 'O'ring and reaches the stop within the connector. This can be visually checked by viewing the push-fit connector outlet (fig.16). Insert locking clips onto hot and cold water push fit connections.

Fitting the Mounting Plate

Ensure that the locking clips are in place before starting this procedure.

Screw the mounting plate onto the push-fit connector until it **reaches the stop** and begins to turn the connector itself (fig.16a and b).

Align the mounting plate fixing holes to the intended position and mark the holes.

Remove the mounting plate. If necessary, hold the push-fit connector stationary when unscrewing the mounting plate.

Drill and plug the wall. An appropriate drill bit should be used. If the wall is brick, plasterboard or a soft building block, appropriate wall plugs and screws should be fitted.

Re-assemble the mounting plate onto the push-fit connector and secure the mounting plate to the wall.

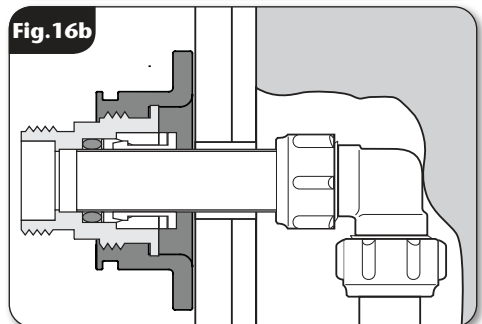
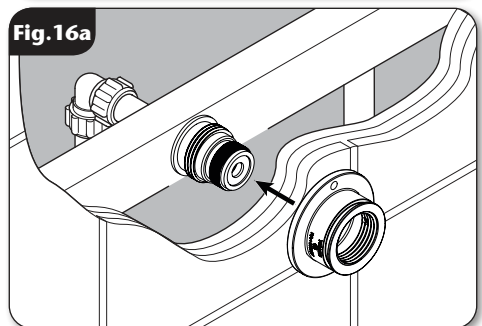
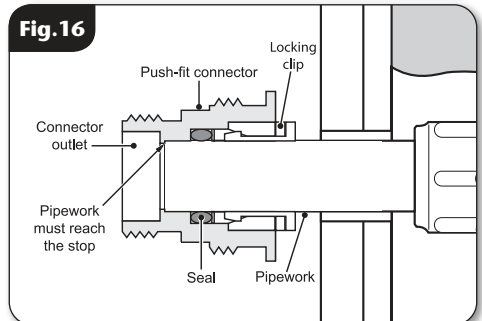
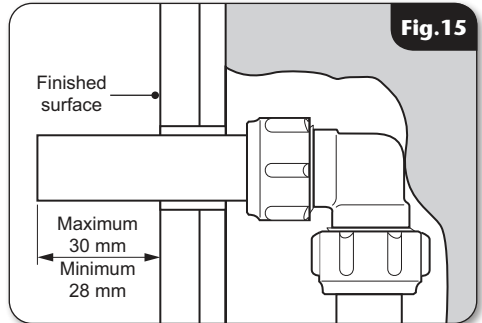

Bar Mixer Shower

Fig.17

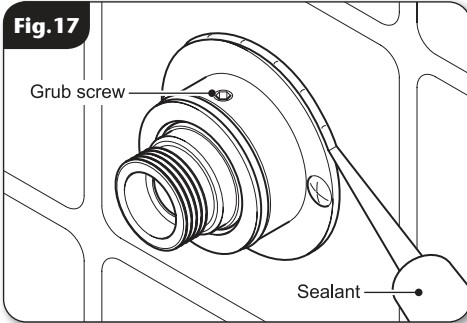

Insert the grub screw into the mounting plate and tighten to secure the connector (**fig.17**). Using a suitable sealant, seal the joint between the mounting plate and the wall or tiles to prevent water entering the wall (**fig.17**). Wipe away any excess sealant which may obstruct the fitting of the cover trim.

Push-fit the cover trims onto the mounting plates. A smear of liquid soap on the seal will ease this procedure (**fig.18**).

Fit the seals into the push-fit connector outlets (**fig.19**).

Fit and secure the bar mixer to the connectors.

Fig.18

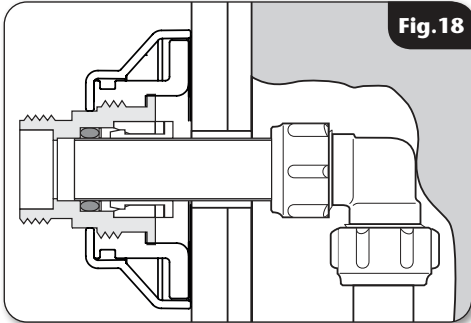

LEAK TESTING

Fit the hose to the outlet and direct it to waste. Open the isolating valves to the shower and check for leaks. Remedy any leaks found.

Fig.19

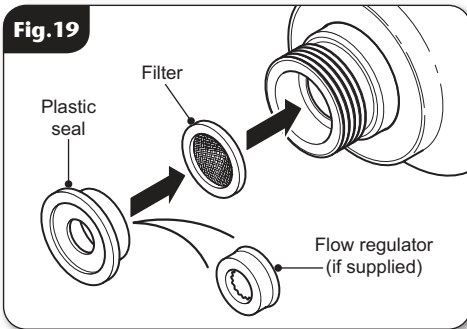

COMMISSIONING

Temporarily fit the hose and perform the commissioning procedure.

Start the water flow by rotating the flow control (left hand side) anti-clockwise.

Make sure that the hot and cold water supplies are fully open and at (or near to) their design temperature and pressures, and are within the requirements as stated on **page 2**.

Make sure the temperature control (right hand side) is at the maximum temperature setting **WITHOUT** operating the maximum temperature override button.

Allow the shower to run at this maximum temperature setting until the water temperature has stabilised.

Rotate the temperature control until your desired maximum showering temperature is reached.

NOTE: If your desired temperature is above the maximum temperature stop limit, please see **Adjusting The Maximum Temperature Stop Setting section.**

A final temperature check **SHOULD** be made on-site to guarantee user safety, and that the mixer falls within recommended maximum mixed water outlet temperatures as stated in the **Temperature Adjustment Range** section.

FLOW REGULATION

A flow regulator is fitted for use with high-pressure water systems. It may be used with any of the systems listed to reduce flow rate and assist economy.

If installing the mixer shower to a water system with a **minimum head of 2 meters or below**, the flow regulator supplied **MUST** be removed.

Using a suitable tool carefully lever the flow regulator from outlet (**fig.20**).

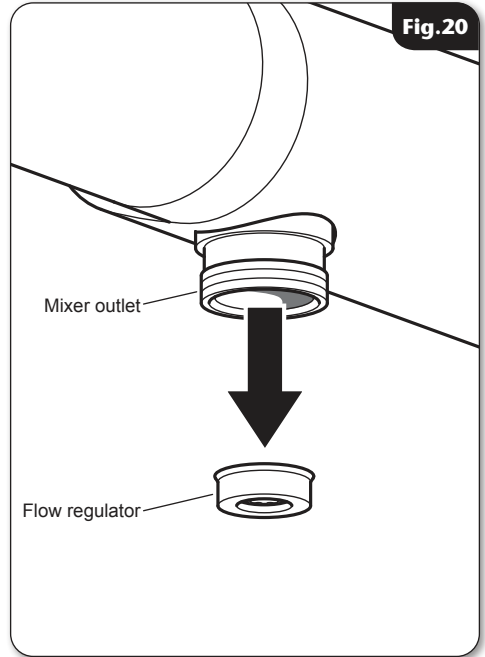

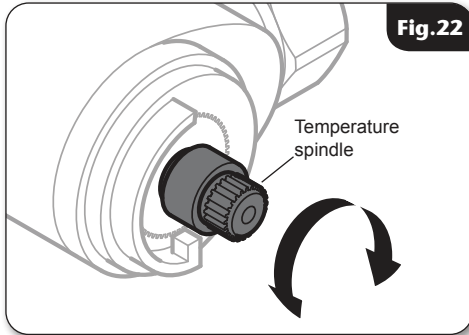
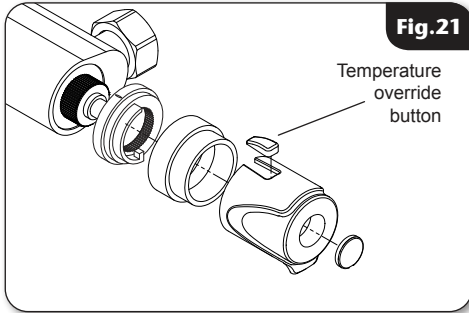

TEMPERATURE ADJUSTMENT RANGE

The mixer shower has a temperature stop to prevent accidental rotation to higher temperatures. This is adjustable to provide a maximum temperature of 35°C – 45°C.

The mixed water temperature can be adjusted from cold through to a top limit (which can be pre-set during installation – factory set at approximately 38°C) with full anti-scald protection throughout the range.

Recommended Outlet Temperatures

The **BuildCert TMV** scheme recommends the following set maximum mixed water outlet temperatures for use in all premises:

44°C - for bath fill but see notes below.

41°C - for showers.

41°C - for washbasins.

38°C - for bidets.

The mixed water temperatures must never exceed **46°C** at terminal fitting.

The British Burns Association recommends **37°** to **37.5°C** as a comfortable bathing temperature for children. In premises covered by the Care Standards Act 2000, the maximum mixed water outlet temperature is **43°C**.

ADJUSTING THE MAXIMUM TEMPERATURE STOP SETTING

Remove the end trim from the temperature control. Undo the retaining screw and pull the temperature control off (**fig.21**).

The maximum temperature stop does not need to be removed.

Turn the flow control to full flow. With a steady flow running, adjust the temperature spindle (**fig.22**) until the temperature is approximately 38°C.

When the showering temperature is satisfactory turn off the shower. Refit the temperature control.

Secure the temperature control in place with the screw and fit the trim.

OPERATING THE SHOWER

To start the shower, rotate the flow control (left-hand side) anti-clockwise. For maximum flow, rotate the flow control anti-clockwise until it stops.

To stop the water flow, rotate the flow control clockwise until the water stops flowing (**fig.23**).

To adjust the water temperature, rotate the temperature control (right-hand side), clockwise for a cooler shower or anti-clockwise for a hotter shower (**fig.24**).

To overcome the maximum temperature stop, depress the temperature override button (**fig24**) on the temperature control and rotate clockwise past the 38°C position.

CAUTION: Exposed metal and chrome surfaces may become hot during use.

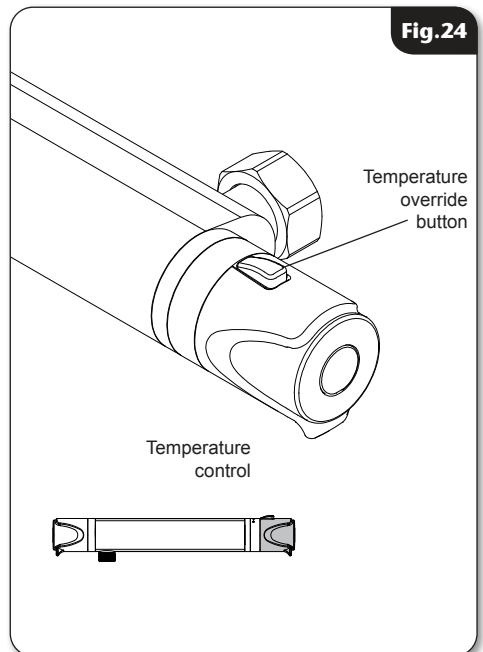
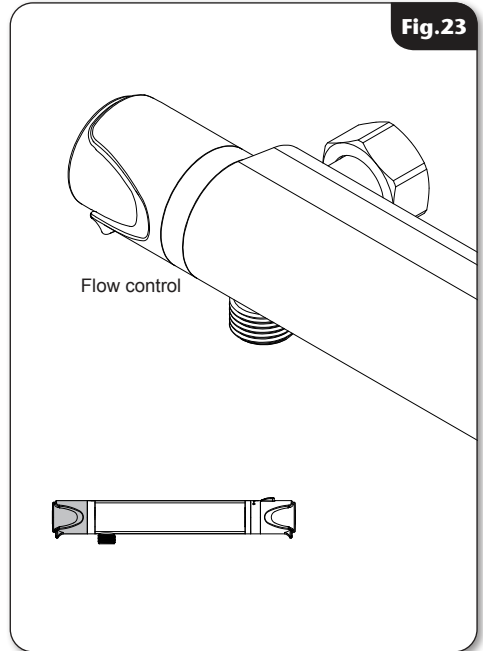

SPARE PARTS

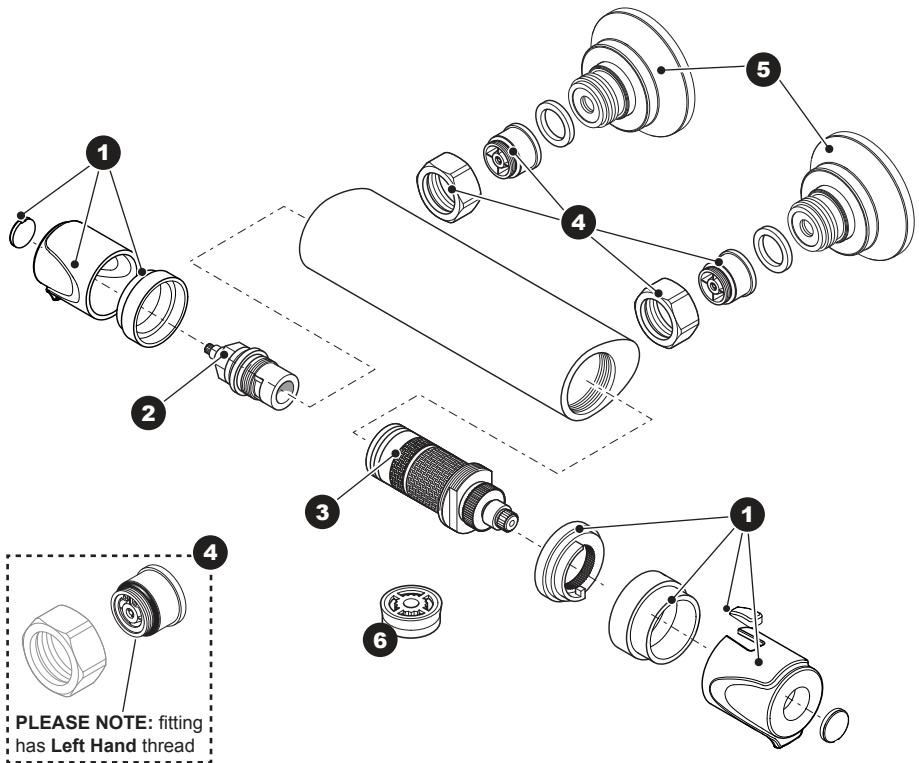

Ref.	Description	Part No.	Ref.	Description	Part No.
1.	Flow Knob & Temp Knob.....	86005010	6.	Flow regulators are available at the following ratings (6 L/M supplied):	
2.	Flow cartridge.....	83315530		Flow regulator 3.0 L/M	22010310
3.	Thermostatic cartridge	83315540		Flow regulator 4.0 L/M	22011740
4.	Non return valve pack.....	83315550		Flow regulator 5.0 L/M	22011750
5.	Bar bracket.....	UNBMXFIXBTCF		Flow regulator 6.0 L/M	22011760
				Flow regulator 7.0 L/M	22011610
				Flow regulator 8.0 L/M	22011280
				Flow regulator 12.0 L/M.....	22013060

TMV2 REQUIREMENTS (12 MONTHLY VERIFICATION)

It is a requirement that all TMV2 approved valves shall be verified against the original set temperature results once a year.

On installation and on a yearly basis please perform the following checks:

1. Cold water supply isolation test

Isolating the cold water supply to the TMV, wait for five seconds if water is still flowing check that the temperature is below **46°C**.

If there is no significant change to the set outlet temperature ($\pm 2^{\circ}\text{C}$ or less change from the original settings) and the fail-safe shut off is functioning, then the valve is working correctly and no further service work is required.

If there is a residual flow during the commissioning or the annual check this is acceptable providing the temperature of the water seeping from the valve is no more than **2C** above the designated maximum mixed water outlet temperature setting of the valve.

Note:

Temperature readings should be taken at the normal flow rate after allowing for the system to stabilise.

The sensing part of the thermometer probe must be fully submerged in the water that is to be tested.

APPROVALS

This mixer valve is approved to the requirements of:

**On pressures above 0.5 bar.*

Designation:

***BS EN 1111**

***WRAS**

HP-S (high pressure shower only)

MAINTENANCE

The following maintenance procedure must be carried out for commercial and health care premises, but is not necessarily required for domestic installations.

Maintenance of the unit is required to give continued performance after installation and that it continues to provide scald prevention.

NOTE: A thermostatic mixing valve in need of maintenance can be undetectable in normal use and only becomes apparent when a disruption occurs in the hot or cold water supply temperatures or pressures.

It is a requirement that all TMV2 approved valves shall be verified against the original set temperature results once every 12 months.

- a) Initially check the filters for debris once every three months and clean if necessary.
- b) Perform a thermal shut off test every three months, and check the maximum temperature setting. See the Commissioning section for the details of this test and readjustment of the maximum temperature setting if required.
- c) If the maximum water temperature varies by more than 2°C from the commissioned setting then carry out the following checks
 - Check the isolating valves are fully open.
 - Check the internal surface for scaling.

If the body requires descaling then it should be removed from the pipework to carry out this work - all rubber parts **MUST** be removed before descaling.

 - Check the function of the non-return valves.

The non-return valves (NRVs) prevent cross-flow between hot and cold supplies under unequal pressure conditions. They are designed for long life with no maintenance.

NOTE: The NRV's will only operate in one direction, water should be able to flow into the unit from the inlets, but NOT back out through the inlets.

If these checks do not highlight the reason for the temperature variation, then internal components will require replacement - please see the Spare Parts list.

Cleaning

It is recommended that all products are cleaned using warm, soapy water.

Do not use abrasive or aggressive chemical cleaning products as this may affect the product surface finish and invalidate your guarantee.

Cleaning the filters (fig.A)

It is advised that this should be carried out by a qualified person.

- Turn off the water supplies before starting.
- To gain access to the filters remove the unit from the inlet fittings.
- Remove the filter housing and disassemble.
- Wash the filters thoroughly under running water, use a suitable brush to remove all debris.
- Reassemble and fit in reverse order.

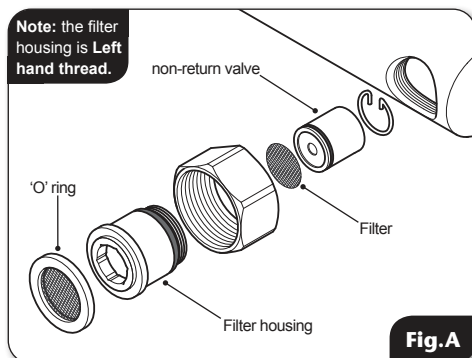

Disinfection

Where chlorine is used for the disinfection of water systems all relevant guidelines and approved codes of practice must be strictly followed. Failure to comply with the relevant guidelines and approved codes of practice may invalidate your guarantee.

WARNING!

DO NOT use powerful abrasive or solvent cleaning fluids when cleaning the shower as they may damage the fittings.

FAULT FINDING

The following can be carried out by a competent person

Problem	Cause	Action
1 Water too hot.	1.1 Temperature control incorrectly commissioned.	1.1.1 Refer to commissioning section.
	1.2 Not enough cold water flowing through shower.	1.2.1 Reposition temperature control knob
	1.3 Increase in the ambient cold water temperature.	1.3.1 Reposition temperature control knob.
	1.4 Cold water supply blocked.	1.4.1 Turn off the shower and consult a competent plumber or contact Customer Experience.
	1.5 High volume of cold water drawn off elsewhere.	1.5.1 Reduce the simultaneous demand from the supply.
2 Water too cold.	2.1 Temperature control incorrectly commissioned.	2.1.1 Refer to the Commissioning section.
	2.2 Not enough hot water flowing through shower.	2.2.1 Reposition temperature control knob
	2.3 Decrease in the ambient cold water temperature.	2.3.1 Reposition temperature control knob
	2.4 Insufficient hot water supplies from the heating system.	2.4.1 Make sure heating appliance is set to maximum or has sufficient stored hot water. 2.4.2 Make sure heating appliance is igniting by trying a hot water tap elsewhere.
	2.5 Hot water supply blocked or restricted.	2.5.1 Turn off shower and consult a competent plumber or contact Customer Experience.
	2.6 Flow regulator not fitted (HP systems only).	2.6.1 Fit suitable flow regulator.
3 High water flow and/or poor performance on a mains fed system.	3.1 Flow regulators not fitted.	3.1.1 Fit suitable flow regulator.

FAULT FINDING

Problem	Cause	Action
4 Water does not flow or shower pattern collapses when another outlet is turned on.	4.1 Water supplies cut off.	4.1.1 Check water elsewhere in house and if necessary contact local water company.
	4.2 Shower unit blocked.	4.2.1 Inspect the inlet filters. Clean if necessary.
	4.3 Blockage in pipework.	4.3.1 Turn off the shower and consult a suitably competent plumber.
	4.4 Showerhead blocked.	4.4.1 Clean showerhead.
	4.5 System not capable of supplying multiple outlets at the same time.	4.5.1 Reduce the simultaneous demand. 4.5.2 Make sure stop/service valves are fully open. 4.5.3 Check if sufficient water pressure.
The following is recommended for a professional qualified installer only		
5 Water too cold.	5.1 Running pressure in excess of maximum recommended.	5.1.1 Fit a pressure reducing valve.
6 Shower controls noisy while in use.	6.1 Running pressure in excess of maximum recommended.	6.1.1 Fit a pressure reducing valve.
7 Shower will not shut off.	7.1 Flow control cartridge worn.	7.1.1 Renew flow control cartridge.

UK SERVICE POLICY

In the event of a product fault or complaint occurring, the following procedure should be followed:

DO NOT REMOVE THE PRODUCT

1. Telephone Customer Experience on **024 7637 2222** having available your details including post code, the model number and power rating of the product, together with the date of purchase and, where applicable, details of the particular fault.
2. If required, the Customer Experience Advisor will arrange for a qualified engineer to call.
3. All products attended to by a Triton service engineer must be installed in full accordance with the Triton installation guide applicable to the product. Every product pack contains an installation guide, however, they can also be downloaded free at www.tritonshowers.co.uk.
4. Our engineer will require local parking and if a permit is required, this must be available to the engineer on arrival at the call.
5. If loft access is required for isolation or to complete a repair, the loft must have a fixed access ladder and be boarded, with appropriate lighting from the access point to and around the repair area.
6. It is essential that you or an appointed representative (who must be over 18 years of age) is present for the duration of the service engineer's visit. If the product is in guarantee you must produce proof of purchase.
7. Where a call under the terms of guarantee has been booked and the failure is not product related (i.e. scaling and furring, incorrect water pressure, pressure relief device operation or electrical/plumbing installation fault) a charge will be made. A charge will also be issued if nobody is at the property when the service engineer calls or adequate parking/permit is not available.
8. If the product is no longer covered by the guarantee an up-front fixed fee will be charged before the site visit.
9. Your receipt must be retained as proof of purchase. Should proof of purchase not be available on an 'in-guarantee' call, or should the service engineer find that the product is no longer under guarantee, the engineer will charge the same fixed price and will request payment prior to departing. If payment is not made on the day an administration charge will be added to the fixed charge.
10. If a debt is outstanding from a previous visit, or from any other Triton purchase, Triton reserves the right to withhold service until the debt has been settled.
11. Triton takes the health, safety and wellbeing of its employees very seriously and expects customers to treat all staff members with respect. Should any employee feel threatened or receive abuse, either verbally or physically, Triton reserves the right to withhold service.

Replacement Parts Policy

In line with AMDEA guidelines, Triton retains functional spares for as long as there is a market for them and in most cases, well beyond. Due to the vast array of product types, the life cycle of products can vary and therefore so can the length of time parts can be supplied. Spare parts can be ordered via our online spare parts store or by telephoning our Triton Customer Experience team on **024 7637 2222**. Payment should be made by credit / debit card (excluding American Express or Diners Card). Payment can also be made by pre-payment of a pro-forma invoice, by cheque or postal order.

Telephone orders are based on information given during the call. Before contacting Triton, please verify your requirements using the information contained in the user guide. Triton cannot accept liability for incorrect part identification.

Triton Showers
Triton Road
Nuneaton
Warwickshire, CV11 4NR

Triton is a division of Norcros Group (Holdings) Limited

Triton reserve the right to change product specification without prior notice. E&OE. © TRITON SHOWERS 2020

TRITON UK STANDARD GUARANTEE

This guarantee applies only to products installed within the United Kingdom and does not apply to products used expressly for commercial gain, unless this use has been specified by Triton. This guarantee does not affect your statutory rights.

With the exception of accessories, Triton guarantee the product against all manufacturing defects for a period of **5 years** for use in a domestic environment from the date of purchase, provided that it has been installed by a competent person in full accordance with the fitting instructions.

All accessories such as shower heads, hoses and riser rails carry a **1 year** parts only guarantee against manufacturing defects.

Any part found to be defective during this guarantee period we undertake to repair or replace at our option without charge, so long as it has been properly maintained and operated in accordance with the instructions and has not been subject to misuse or damage or the effects of limescale build up. This product must not be taken apart, modified or repaired except by a person authorised by Triton.

What is not covered:

1. Breakdown due to:
 - a) use other than domestic use by the property occupants;
 - b) wilful act or neglect;
 - c) any malfunction resulting from the incorrect use or quality of electricity, gas or water or incorrect setting of controls;
 - d) failure to install in accordance with this installation guide.
2. Claims for missing parts once the product has been installed.
3. Repair costs for damage caused by foreign objects or substances.
4. Total loss of the product due to non-availability of parts.
5. Compensation for loss of use of the product or consequential loss of any kind.
6. Call out charges due to an abortive visit or where no fault has been found with the appliance.
7. The cost of repair or replacement of isolating switches, electrical cable, fuses and/or circuit breakers or any other accessories installed at the same time. Replacement of the Pressure Relief Device that only activates when the shower outlet is blocked is also excluded.
8. The cost of routine maintenance, adjustments, overhaul modifications or loss or damage arising therefrom, including the cost of repairing damage, breakdown, malfunction caused by corrosion, furring, frost or exposure to freezing conditions.
9. Call out charges where the water supply cannot be isolated, this includes consequential losses arising from unserviceable supply valves, or inaccessible product or valves located in a loft space without suitable access.

For the latest Terms & Conditions please see:

www.tritonshowers.co.uk/terms

PLEASE NOTE PRODUCT REGISTRATION IS ONLY AVAILABLE TO UNITS PURCHASED & INSTALLED IN THE UK

Customer Experience: **024 7637 2222**

Trade Installer Hotline: **024 7637 8344**

www.tritonshowers.co.uk

E-mail: serviceenquiries@tritonshowers.co.uk

E-mail: technical@tritonshowers.co.uk